



Installation instructions, accessories

Volvo Car Corporation Gothenburg, Sweden

Instruction No	Version	Part. No.
31428063	1.0	31428061, 31428882

Parking assistance, camera, rear

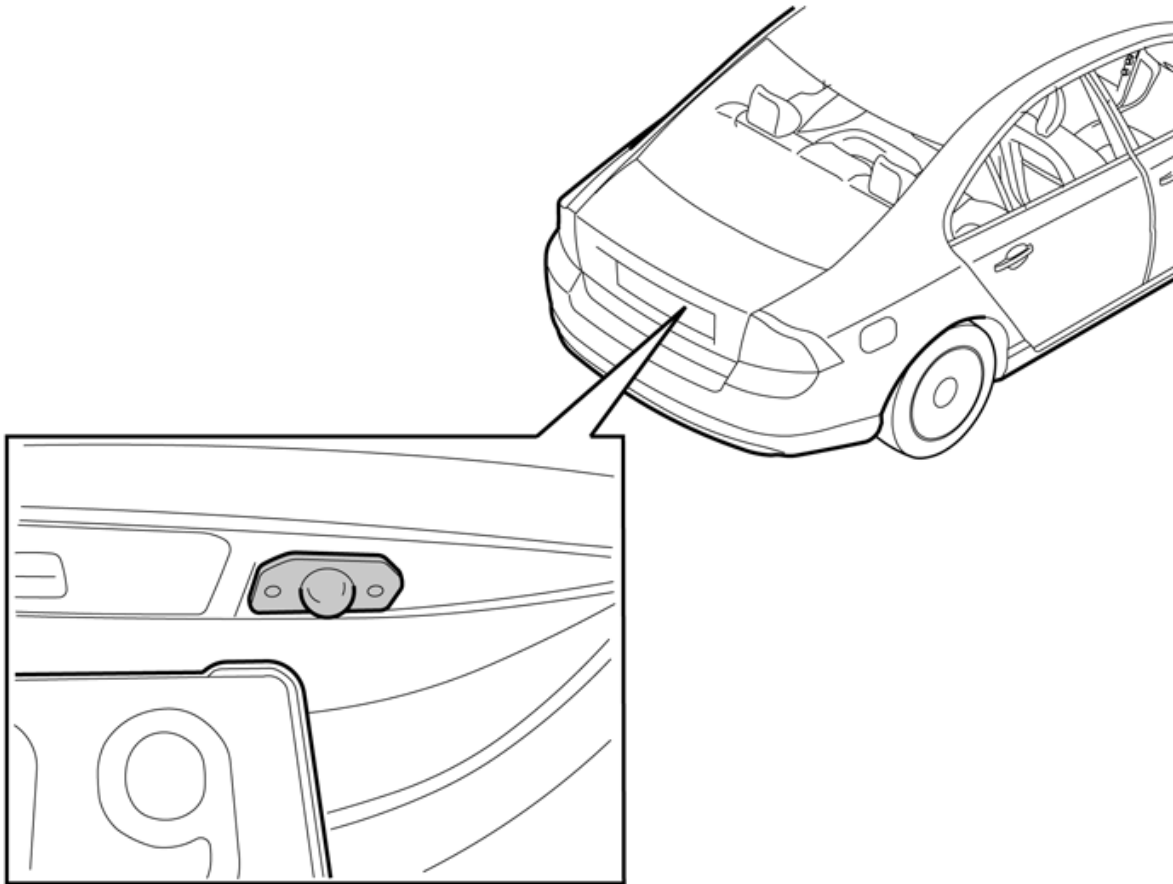

IMG-258000



Installation instructions, accessories

Volvo Car Corporation Gothenburg, Sweden

Equipment

VIDA

IMG-242205

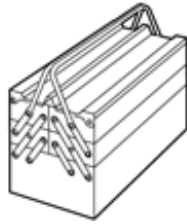

IMG-345497



IMG-239664

Nm
lbf.ft



A0000192



IMG-239660



VOLVO
9512943

IMG-239446



IMG-332313

48 h

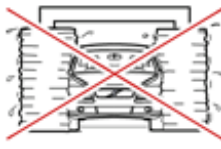

IMG-333293

2 h



IMG-333288

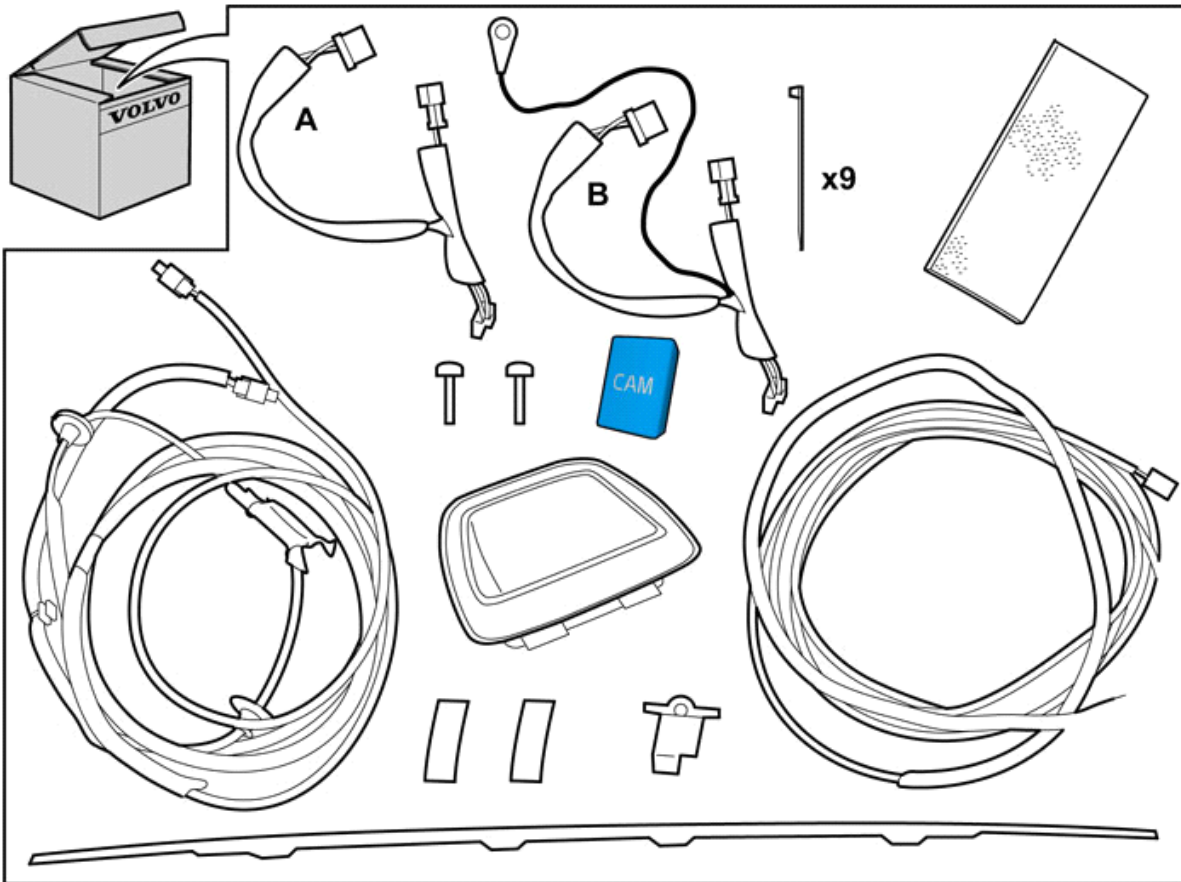

IMG-353696



Installation instructions, accessories

Volvo Car Corporation Gothenburg, Sweden

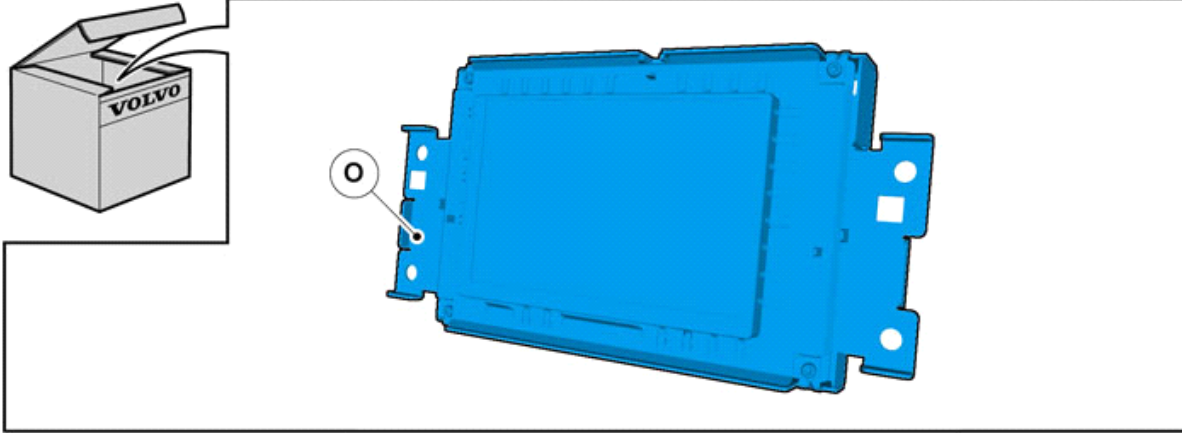

IMG-346651



Installation instructions, accessories

Volvo Car Corporation Gothenburg, Sweden

INTRODUCTION

Read through all of the instructions before starting installation.

Notifications and warning texts are for your safety and to minimise the risk of something breaking during installation.

Ensure that all tools stated in the instructions are available before starting installation.

Certain steps in the instructions are only presented in the form of images. Explanatory text is also given for more complicated steps.

In the event of any problems with the instructions or the accessory, contact your local Volvo dealer.

Note!

Some steps in these installation instructions are presented with illustration only.

Preparations

1

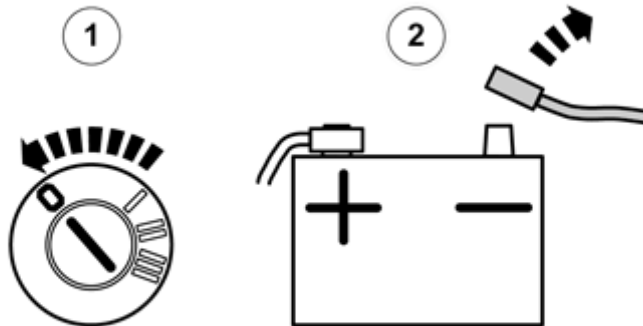

Preparations

Place the left front seat in its rearmost position.

Set the ignition key to position **0**.

Disconnect the battery negative lead.

Note!

Wait at least one minute before unplugging the connectors or removing other electrical equipment.

IMG-335491



Installation instructions, accessories

Volvo Car Corporation Gothenburg, Sweden

2

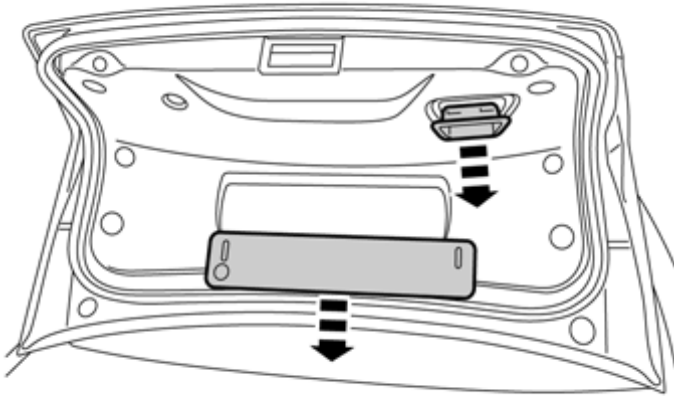

IMG-254043

Remove the warning triangle from the trunk lid panel.

Remove the trunk lid's inner handle by first sliding it upwards and then bending it out at the lower edge using a weatherstrip tool.

Note!

The inner handle will no longer be used, there is a new handle in the kit.

3

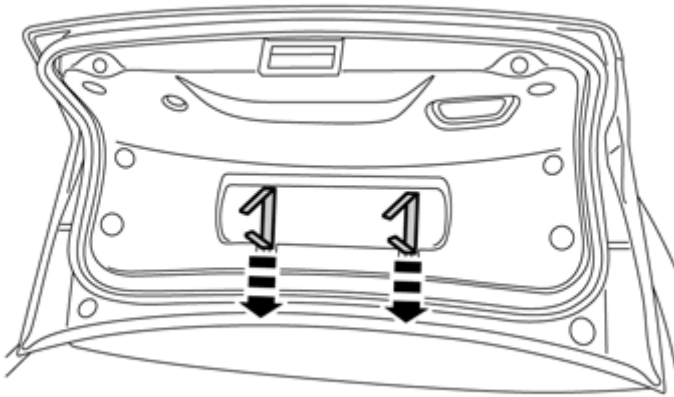

IMG-254044

Pull out the central pin from the clips for the warning triangle's holder and remove them.

4

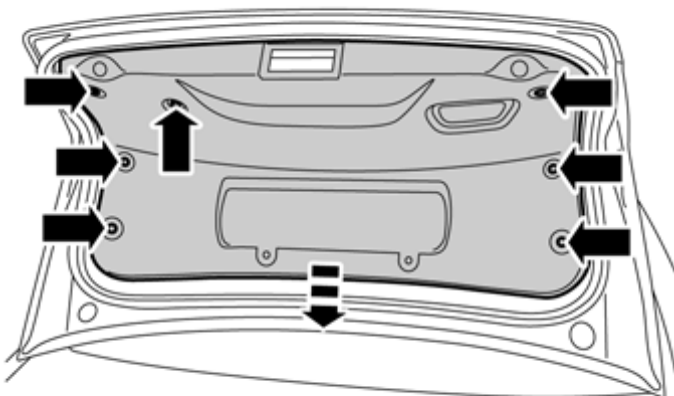

IMG-254045

Remove the clips from the trunk lid's panel and remove the panel.



Installation instructions, accessories

Volvo Car Corporation Gothenburg, Sweden

5

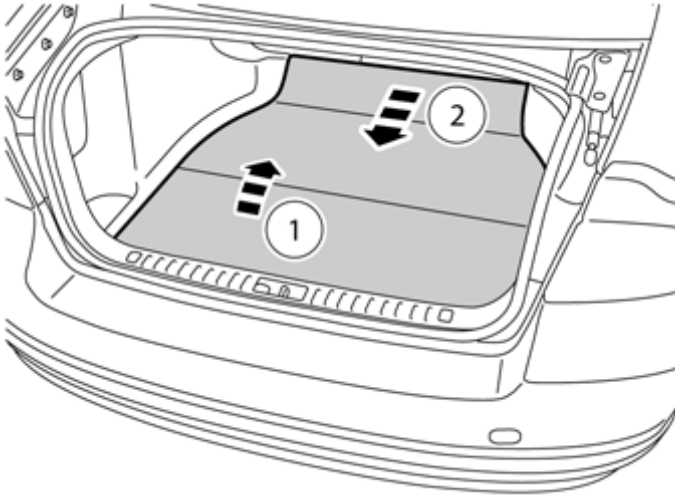

Fold together the cargo compartment carpet (1, 2) and remove it.

IMG-249177

6

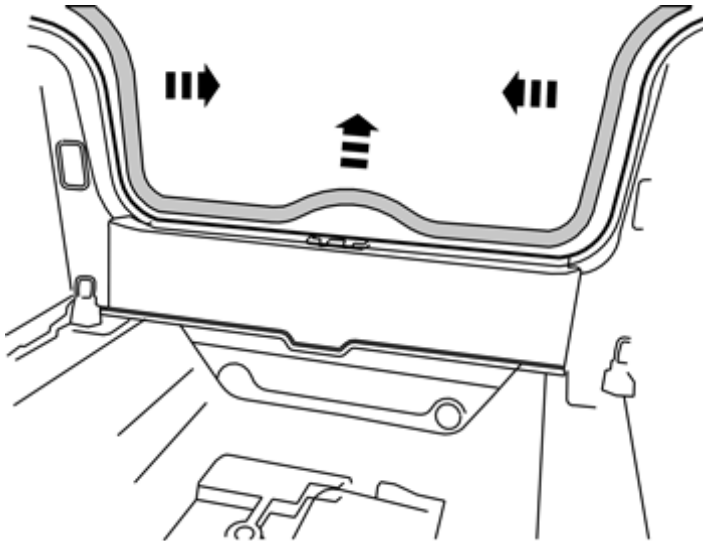

Detach the rubber weatherstrips from the trunk lid opening.

IMG-226721

7

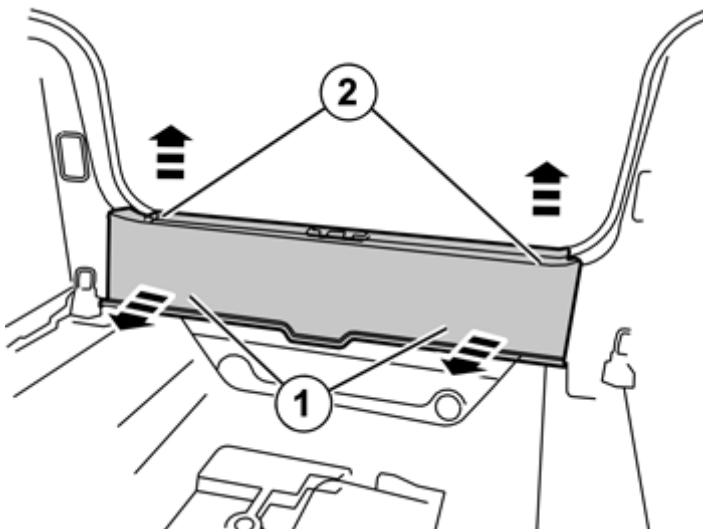

Remove the trunk lid's sill trim panel. It is secured by two clips at the front edge (1) and two at the upper edge (2).

IMG-226722



Installation instructions, accessories

Volvo Car Corporation Gothenburg, Sweden

8

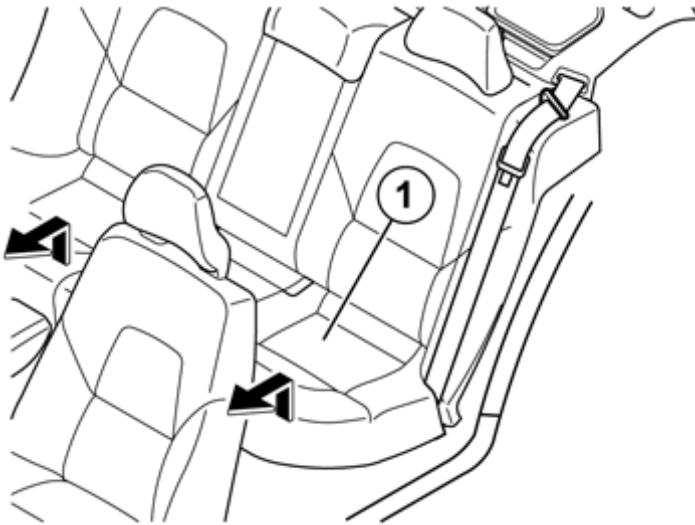

IMG-254103

Remove the seat cushion (1) by pulling up its front edge, pulling it forwards and then lifting it out.

Detach the two connectors for seat heating underneath the seat cushion.

9

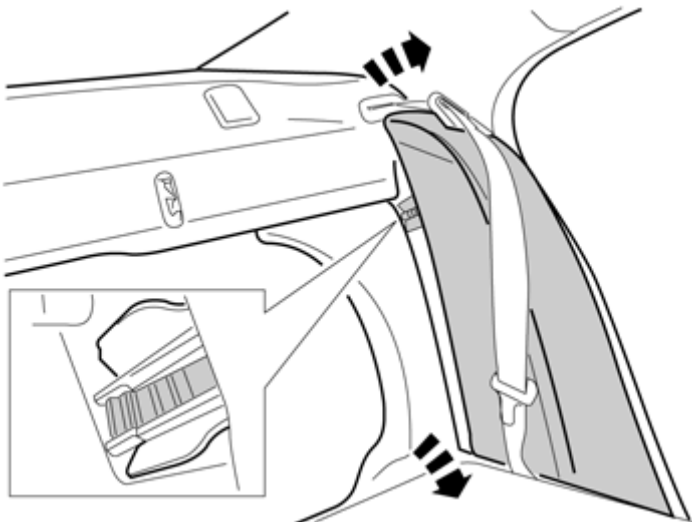

IMG-257670

Fold the backrest forward.

Remove the seatbelt from the guide (1) on the side bolster.

Insert a hand from the side of the upper section of the side bolster. Press in the catches properly and jerk the upper edge of the bolster so that the two catches on the other side release. Lift the bolster from the mounting at the lower edge.



Installation instructions, accessories

Volvo Car Corporation Gothenburg, Sweden

10

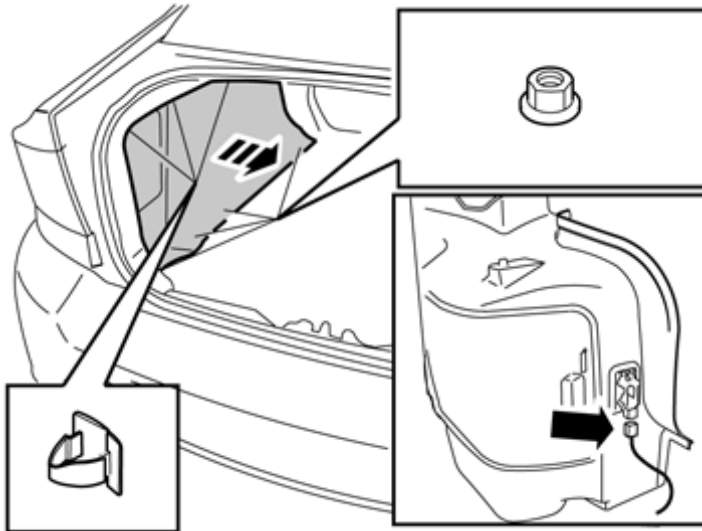

IMG-254105

Remove the three clips at the upper edge of the side panel and the four plastic nuts at the lower edge.

Remove the cargo compartment lighting connector.

Lift out the side panel.

Repeat for the other side.

11

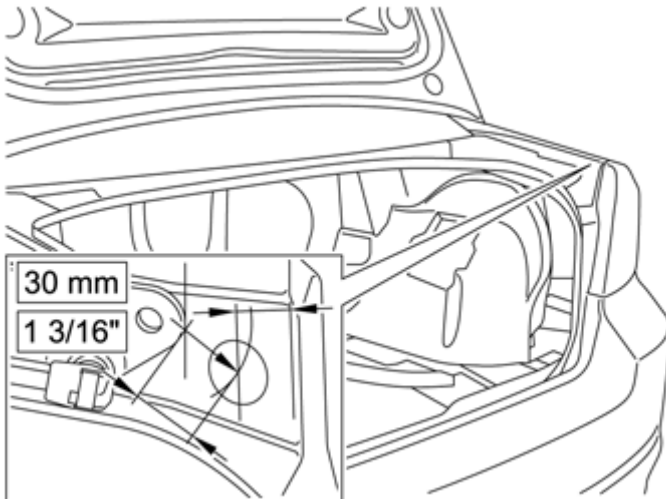

IMG-254106

Measure a distance of **30 mm (1 3/16 ")** from the rear edge of the rear fender and mark out a short line parallel to the rear edge. Use a piece of tape to make the markings on.

Measure **30 mm (1 3/16 ")** from the rear edge of the gas cylinder's bracket to the previously drawn line. Mark out the middle of the hole that is to be drilled where the lines cross each other.

Pre-drill the hole using a **Ø3 mm (1/8")** bit.

Note!

Use a **5 mm (3/16 ")** drill stop.

Drill out the hole to **Ø8 mm (5/16 ")** and then to **Ø12 mm (15/32 ")** to be able to insert the pull screw through for the hole making tool.

Note!

Do not damage surrounding painted surfaces.

Remove any swarf.



Installation instructions, accessories

Volvo Car Corporation Gothenburg, Sweden

12

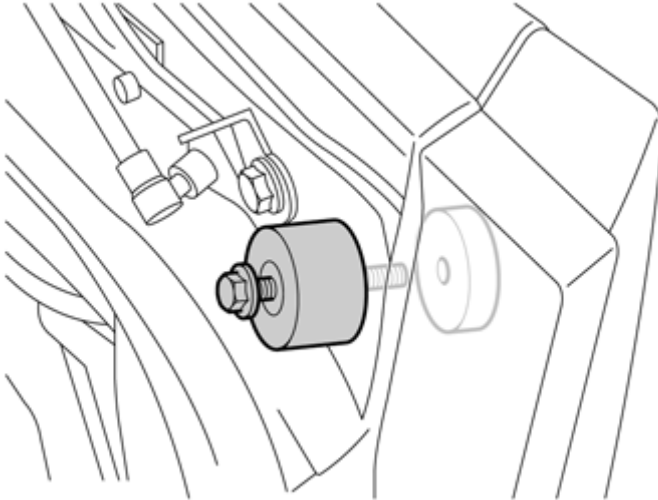

IMG-254107

Use holesaw bit, **part.no 9997241 (Ø28.6 mm (1 1/8"))**, and enlarge the hole.

File down the edges of the holes.

Remove any swarf.

Apply primer **part no. 9437350** around the hole edges and allow to dry.

13

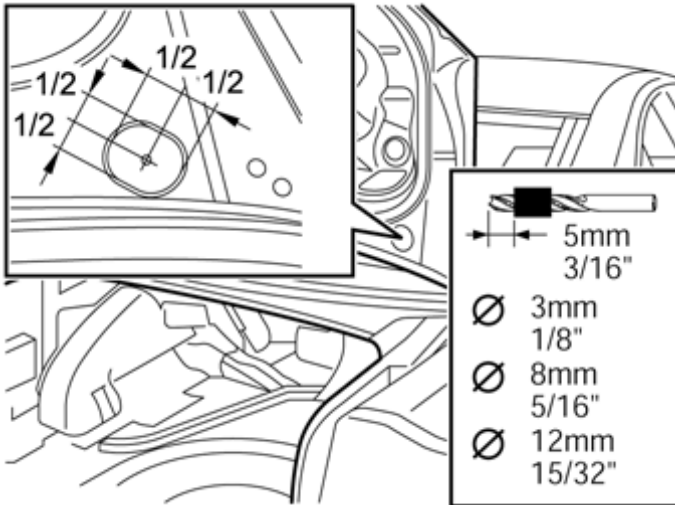

IMG-254108

Measure for making holes for the rubber grommets in the trunk lid's front right-hand corner according to the diagram and mark out the middle.

Pre-drill the hole using a **Ø3 mm (1/8")** bit.

Note!

Use a **5 mm (3/16 ")** drill stop.

Drill out the hole to **Ø8 mm (5/16 ")** and then to **Ø12 mm (15/32 ")** to be able to insert the pull screw through for the hole making tool.

Note!

Do not damage surrounding painted surfaces.

Remove any swarf.



Installation instructions, accessories

Volvo Car Corporation Gothenburg, Sweden

14

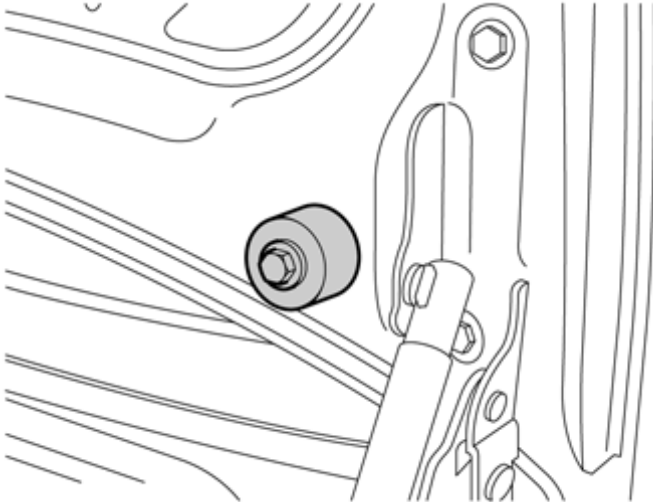

IMG-254109

Use holesaw bit **part no. 9997241 (Ø28.6 mm (1 1/8"))** and enlarge the hole.

File down the edges of the holes.

Remove any swarf.

Apply primer **part no. 9437350** around the hole edges and allow to dry.

15

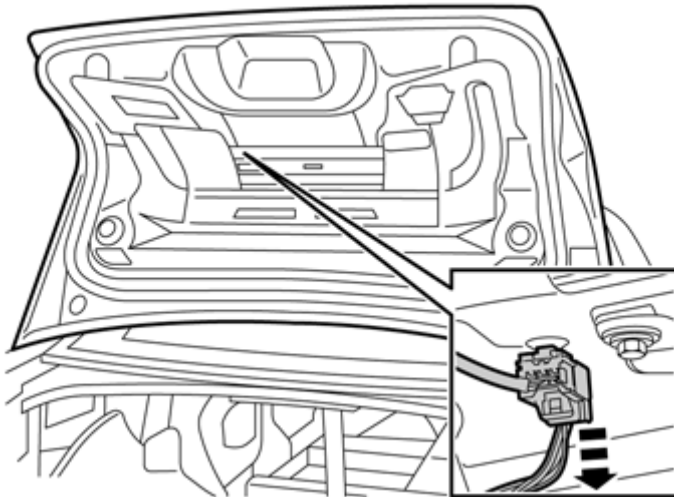

IMG-254110

Disconnect the connector for number plate lighting.

16

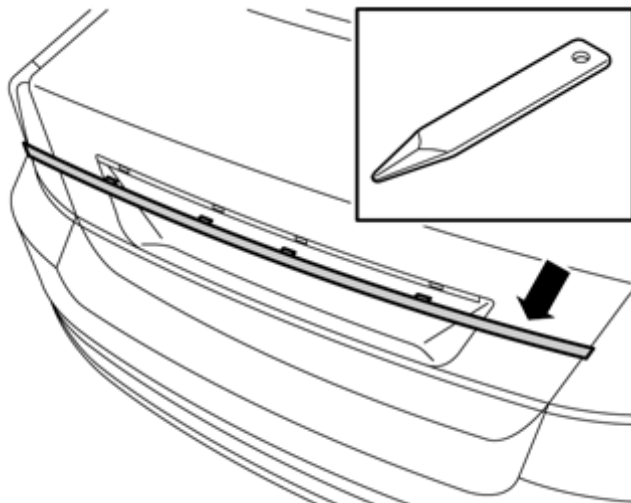

IMG-254111

Remove the trunk lid's trim strip by carefully prying it off from the trunk lid and number plate lighting's panel. It is securely fastened and will eventually break. New strip included in the kit.

Remove any tape residue from the trunk lid by heating the steel with a hot air gun. Do not heat above 80° C.



Installation instructions, accessories

Volvo Car Corporation Gothenburg, Sweden

17

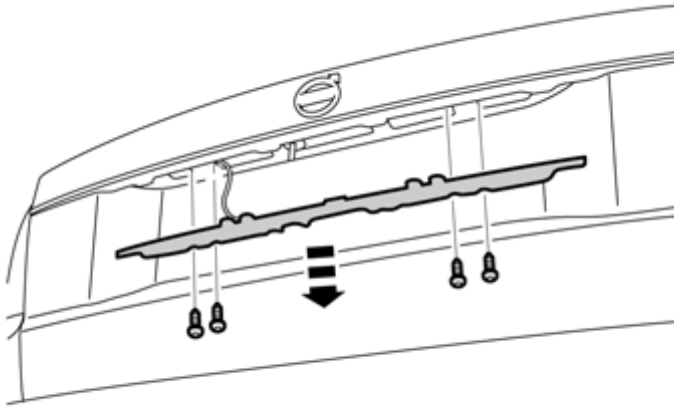

Remove the four screws from the number plate lighting panel and remove it.

Remove the parts of the trim strip if it has broken.

IMG-254112

18

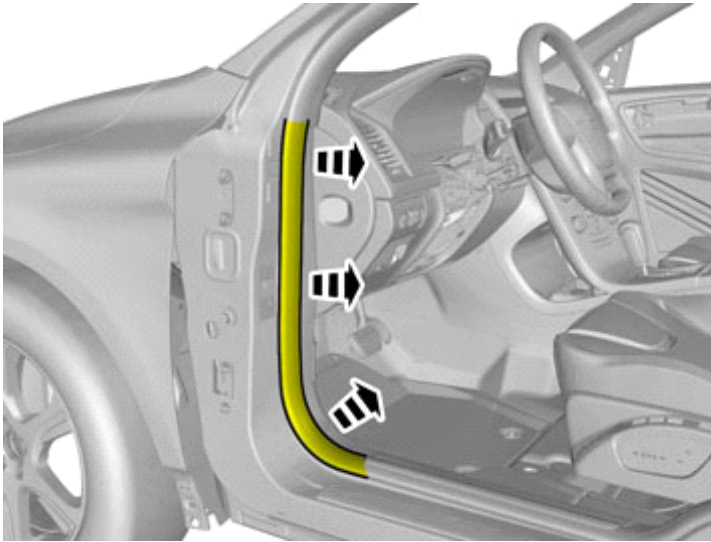

Remove the rubber strip.

IMG-346689

19

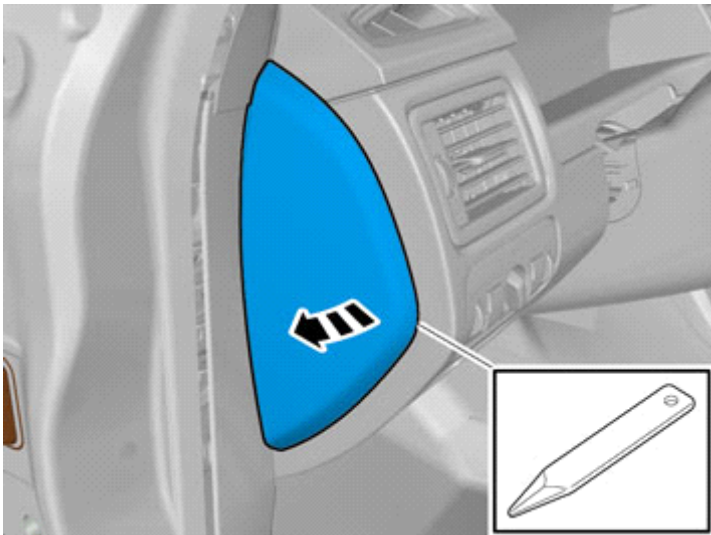

Remove the panel.

IMG-338119



Installation instructions, accessories

Volvo Car Corporation Gothenburg, Sweden

20

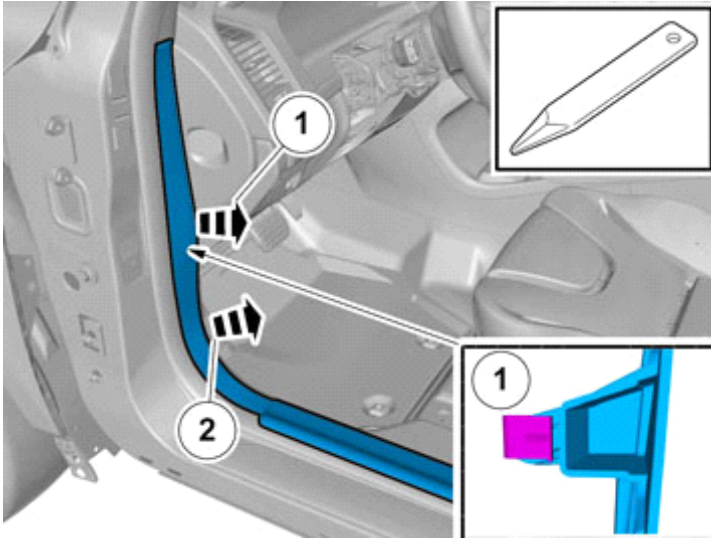

IMG-346676

21

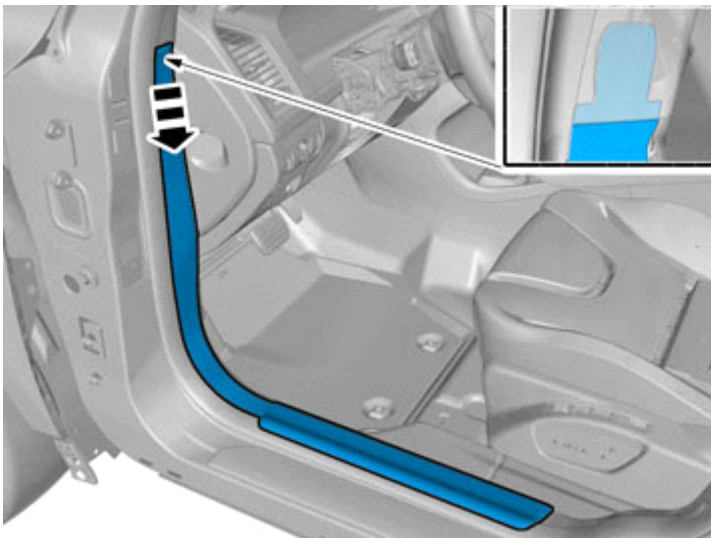

IMG-346681



Installation instructions, accessories

Volvo Car Corporation Gothenburg, Sweden

22

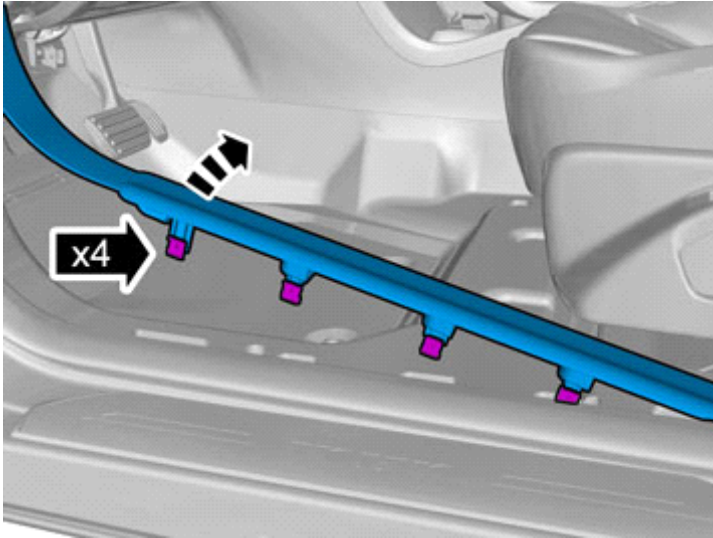

IMG-346677

23

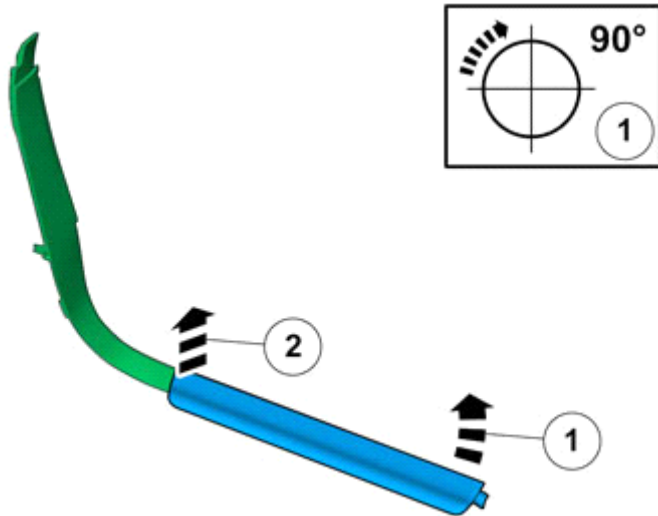

IMG-346682

24



M8502823

Remove the sill panel in the door opening for the left-hand rear door by carefully pulling it upwards until the four clips release.



Installation instructions, accessories

Volvo Car Corporation Gothenburg, Sweden

25

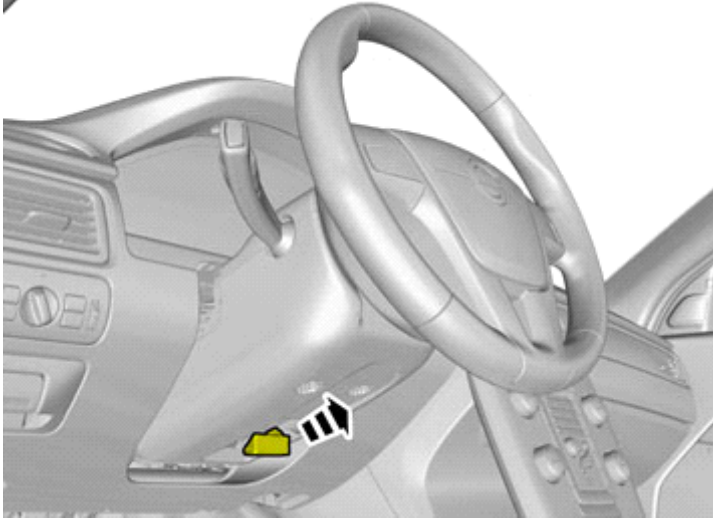

IMG-344717

Release the catch.

26

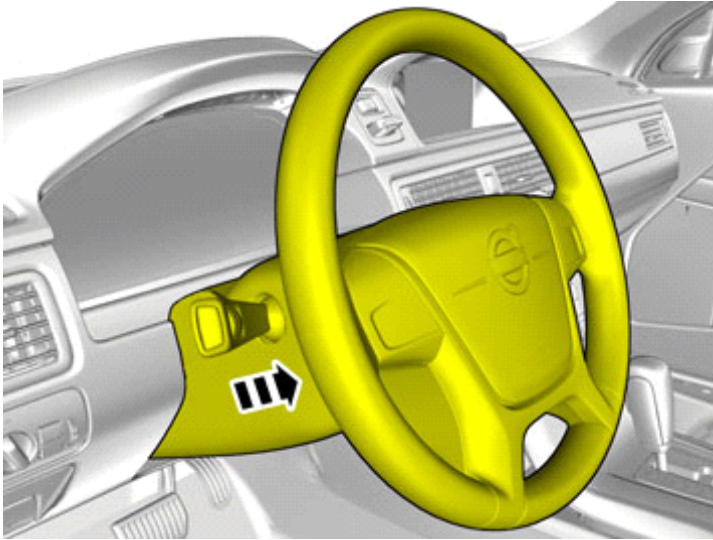

IMG-344721

27

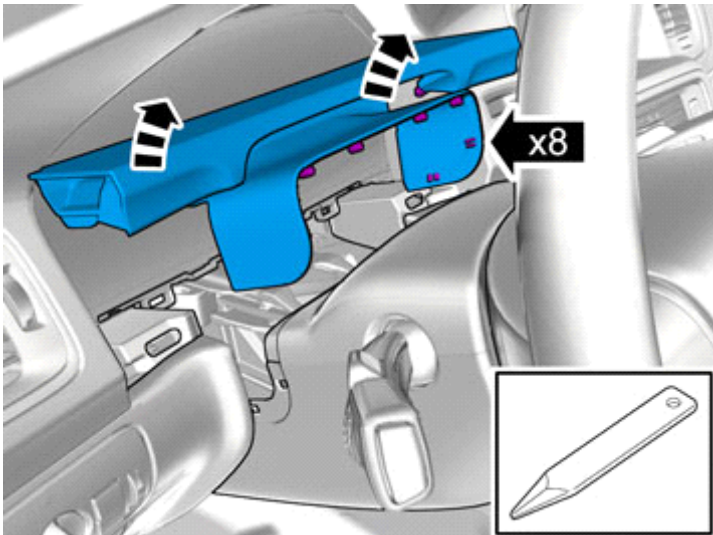

IMG-344722

Remove the panel.



Installation instructions, accessories

Volvo Car Corporation Gothenburg, Sweden

28

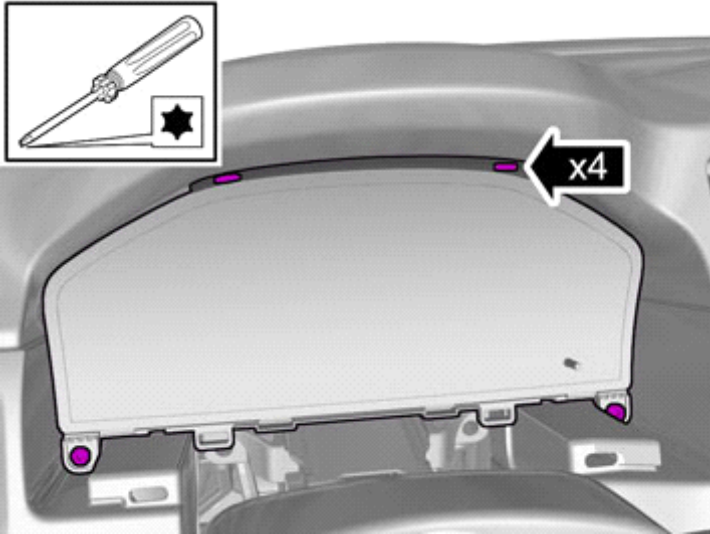

IMG-341879

Remove the screws.

29

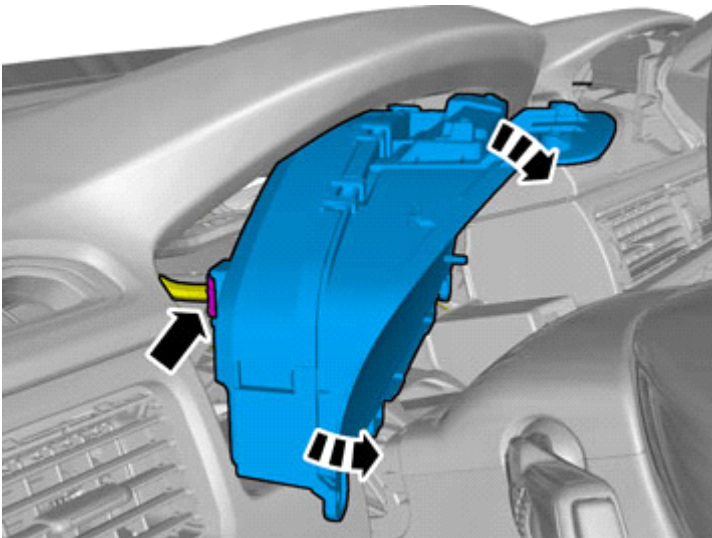

IMG-341941

Unplug the connector.



Installation instructions, accessories

Volvo Car Corporation Gothenburg, Sweden

30

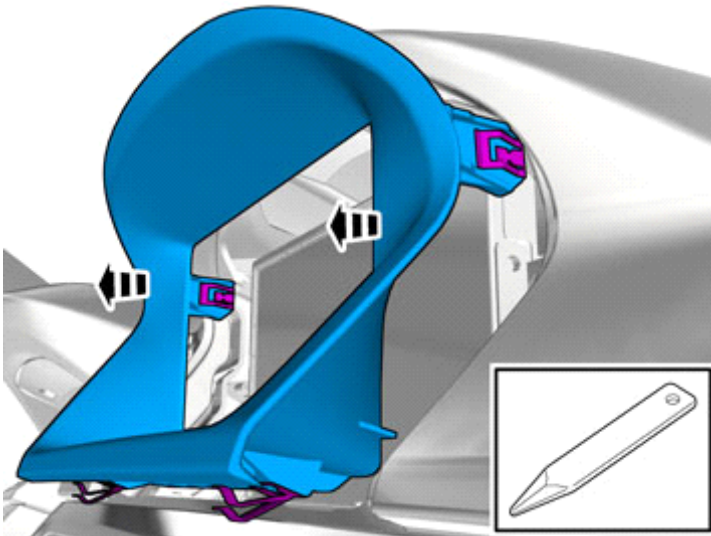

IMG-349876

Remove the panel.

31

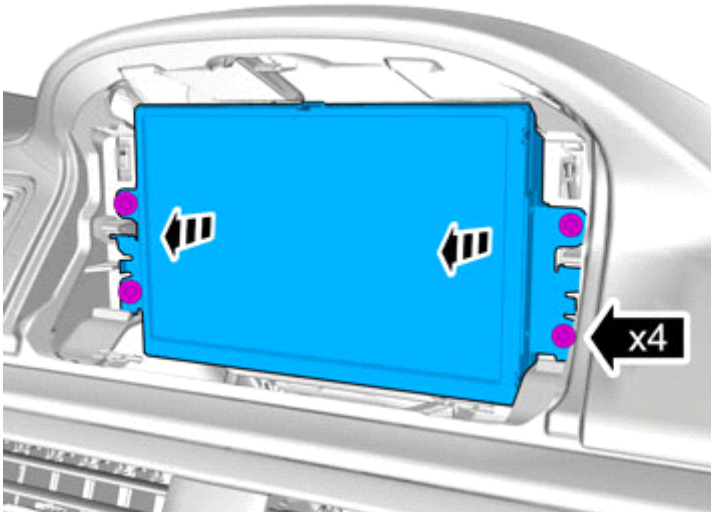

IMG-349877

Remove the screws.

Remove the panel.

32

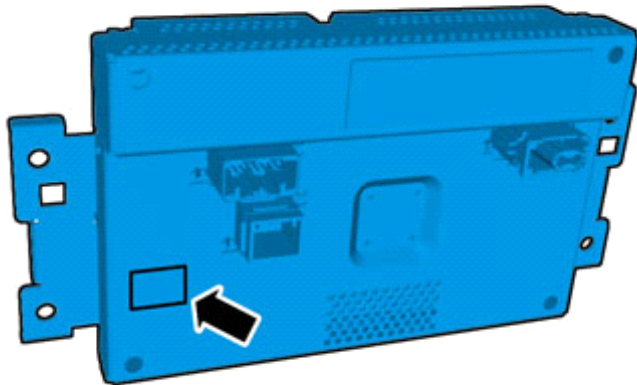

IMG-348526

Vehicles with 5 inch ICM display

Note!

If there is no connection, replace the display.



Installation instructions, accessories

Volvo Car Corporation Gothenburg, Sweden

33

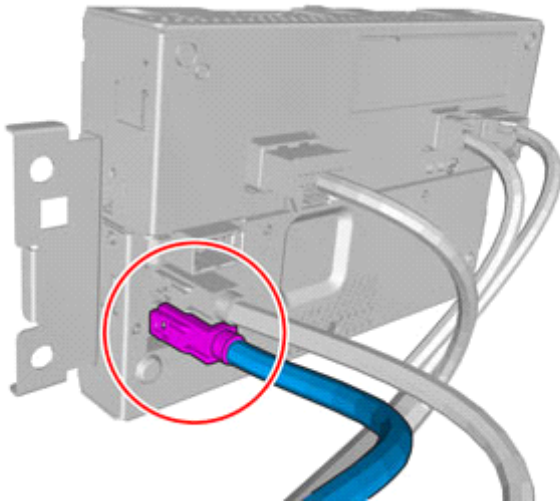

IMG-352166

Vehicles with 7 inch display

Disconnect the connector, if applicable.

Use electrical tape to secure the connector in the existing cable.

34

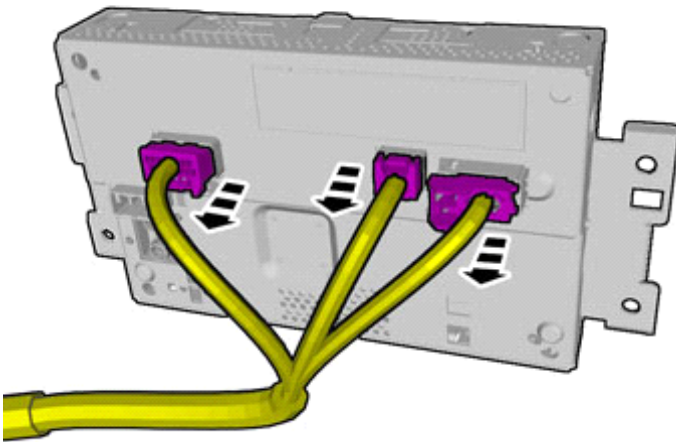

IMG-345776

Note!

The number of connectors, cables and cable ties can vary in the vehicle's equipment level.

Unplug the connectors.

Installing the parking camera



Installation instructions, accessories

Volvo Car Corporation Gothenburg, Sweden

35

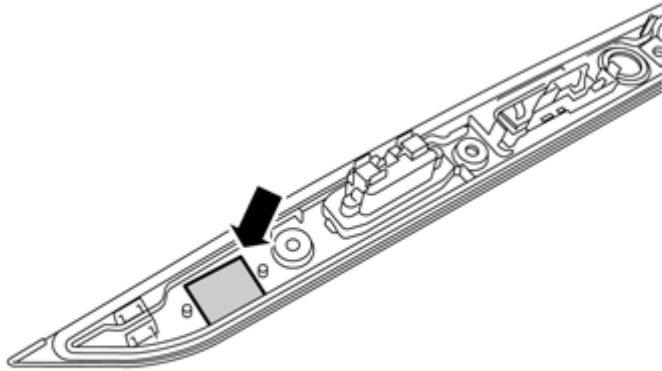

IMG-255733

Installing the parking camera

Drill/cut out a hole for the camera in the number plate lighting panel. Then remove the existing markings on the inside of the panel (see image).

Even off the edges carefully using a fine-toothed file.

Note!

Take care not to knock the surface that the camera is to be screwed to or to scratch it so that the seal becomes impaired.

36

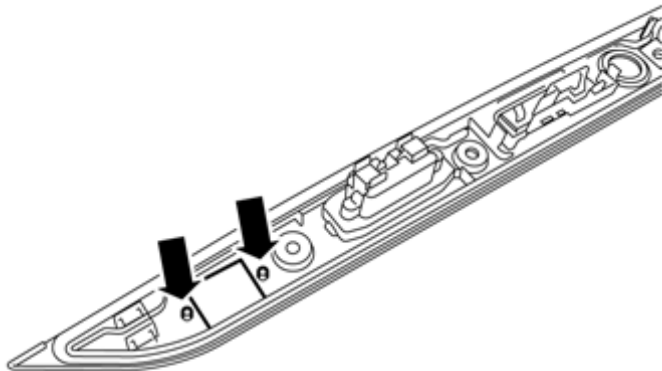

IMG-255734

Drill out the holes in the protruding lugs using a **Ø2.5 mm (3/32")** drill bit.

Remove any swarf.

37

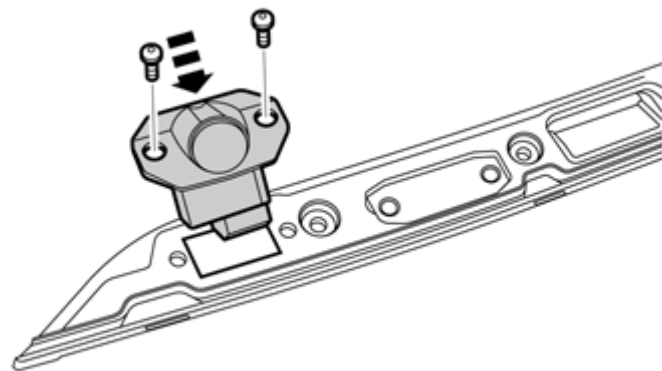

IMG-255735

Take two screws and the camera with the seal from the kit.

Screw the screws into the holes on the camera completely so that they rotate freely.

Insert the camera into the hole and screw it into place by tightening the screws crosswise so that the camera is tightened parallel to the panel.



Installation instructions, accessories

Volvo Car Corporation Gothenburg, Sweden

38A

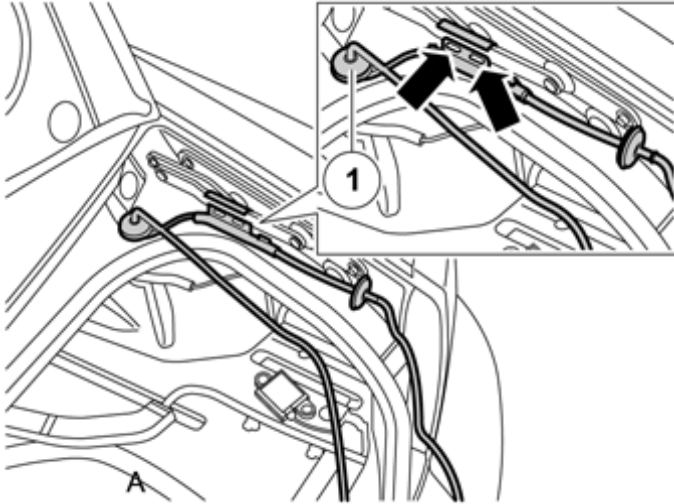

Illustration A

Take the cable harness with the two rubber grommets from the kit. The rubber grommet (1) with the shorter cable end must go through the trunk lid.

Hook the cable holder onto the inner lower edge of the hinge section.

Illustration B

Place the cable holder so that the stop in the upper edge locates in the cut-out on the hinge.

Press the cable holder so that the upper section engages in the upper edge of the hinge.

IMG-255736

38B

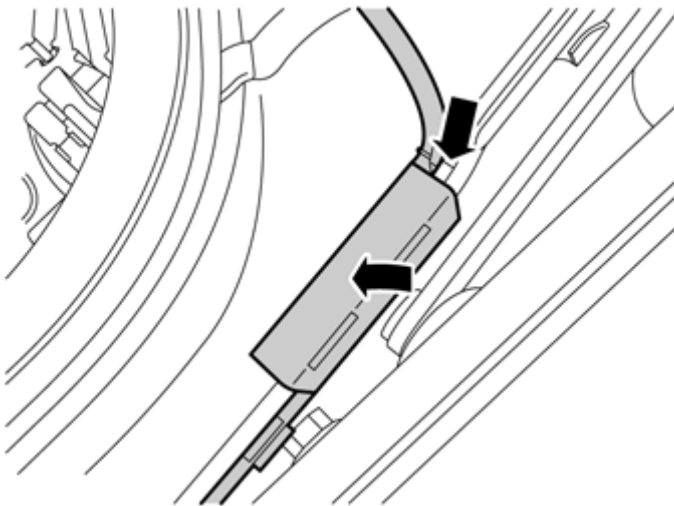

IMG-255737

Insert the longer of the cables in the hole on the rear fender and press the rubber grommet securely into place. Ensure that the primer around the hole edges is not damaged.

Note!

Do not damage the rustproofing agent around the hole edges.

39

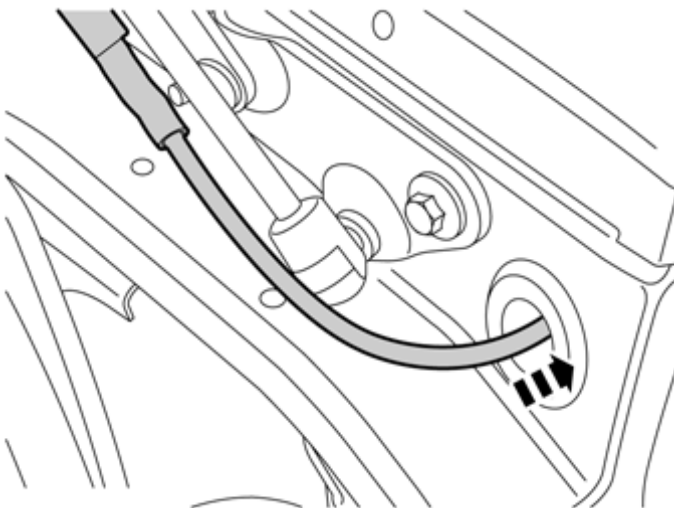

IMG-255738



Installation instructions, accessories

Volvo Car Corporation Gothenburg, Sweden

40

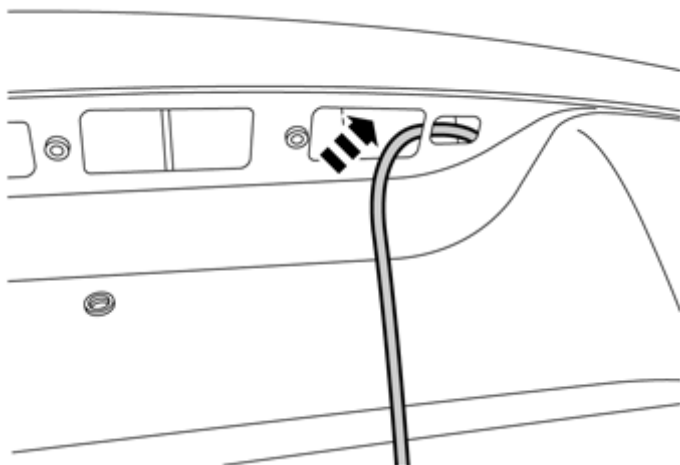

IMG-256323

Insert a wire into the right-hand hole on the trunk lid where the panel for the number plate lighting is, and pull it forwards in the hole on the trunk lid.

41

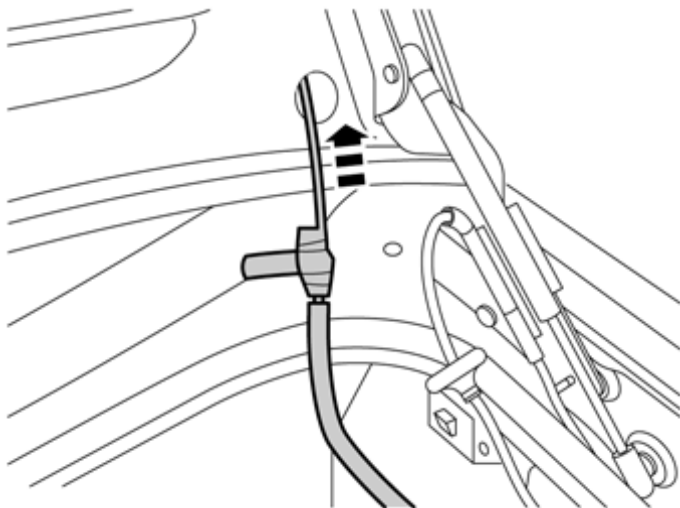

IMG-255739

Bind the connector to the shorter cable at the routed wire using tape.

Pull up the cable through the trunk lid and pull it out through the hole.

42

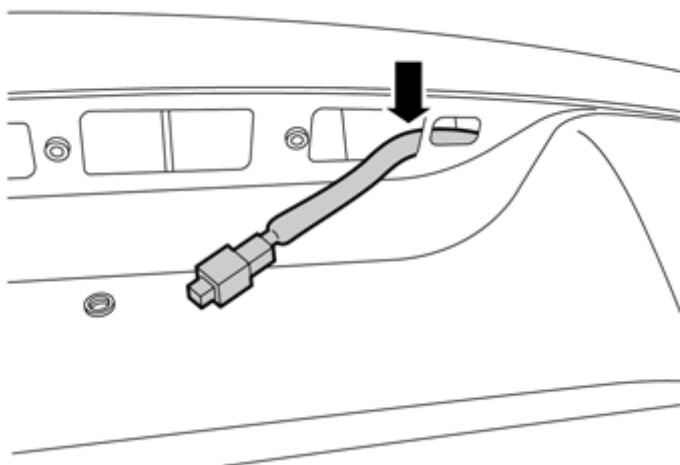

IMG-255740

Disconnect the cable from the wire.



Installation instructions, accessories

Volvo Car Corporation Gothenburg, Sweden

43

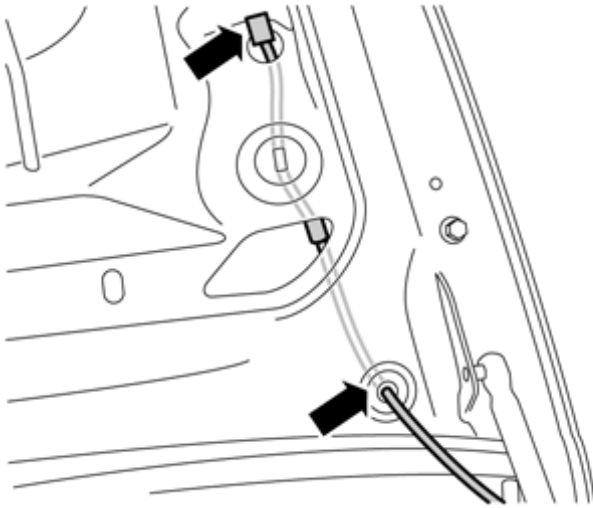

IMG-255741

Press the rubber grommet into the trunk lid securely.

Note!

Do not damage the rustproofing agent around the hole edges.

Take the cable with the edge clip from the oval hole in the trunk lid and press the clip onto the hole edge.

Note!

Check that the cable is not over stretched between the trunk lid and the fender when the trunk lid is full open. Adjust the length of the cable in the rubber grommets.

44

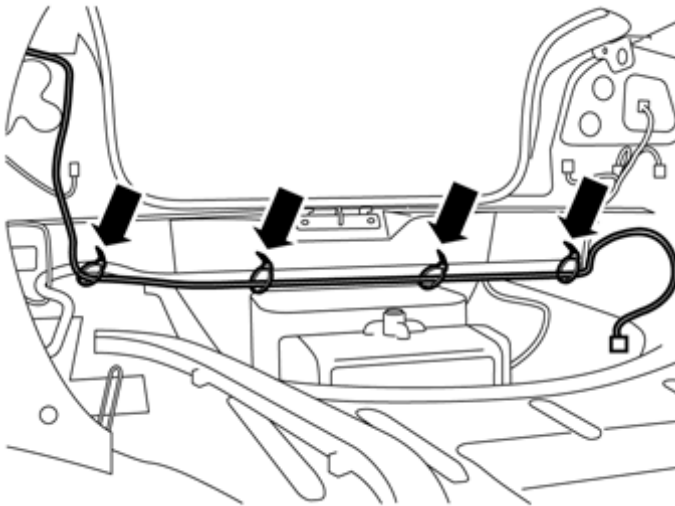

IMG-255742

Pull the cable down from the rubber grommet in the rear fender and along the existing cable harness to the left-hand tail lamp.

Clamp the cable using tie straps from the kit as illustrated.



Installation instructions, accessories

Volvo Car Corporation Gothenburg, Sweden

45

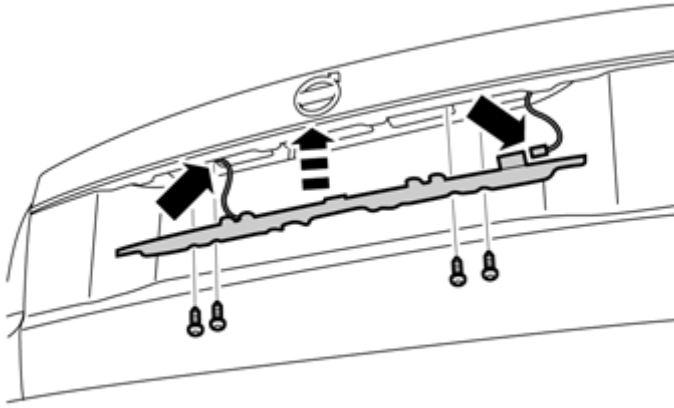

IMG-255743

Take the camera equipped panel for the number plate lighting.

Connect the connector to the routed cable harness for the reversing camera.

Guide the cable for the number plate lighting through the hole in the trunk lid.

Reinstall the panel and tighten. Ensure that the cables for the number plate lighting are not trapped.

46

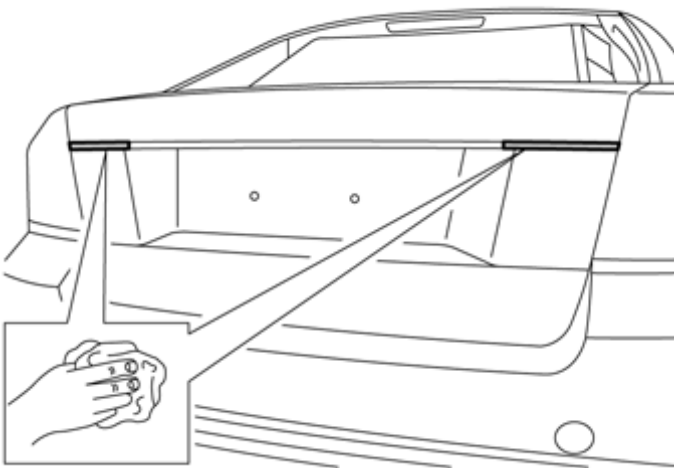

IMG-255744

Use isopropanol and clean the marked surface on the boot lid where the chrome strip tape will sit. Wipe dry.

47

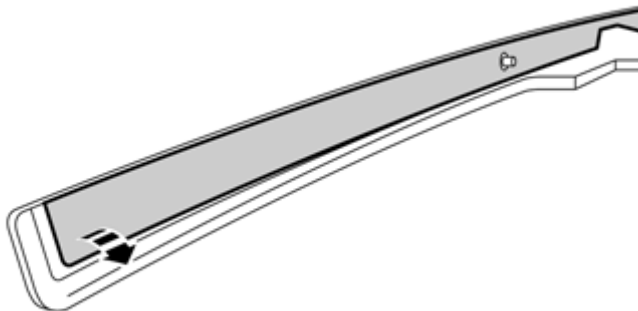

IMG-255745

Take the new trim strip from the kit. Remove the protective film from the adhesive tape.



Installation instructions, accessories

Volvo Car Corporation Gothenburg, Sweden

48

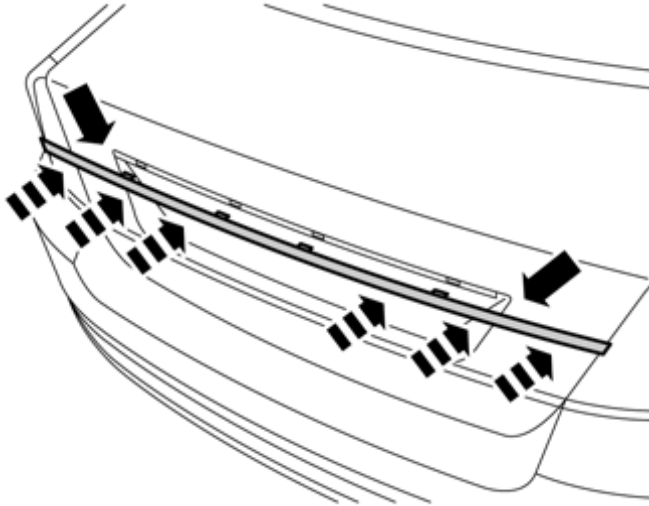

IMG-255746

Note!

During installation the underlying surface must be kept at a temperature of at least +15°C (59°F).

Insert the trim strip clips in the corresponding holes on the panel. Ensure that the strip's locating pins align with the holes on the trunk lid.

Press the strip firmly along the entire length of the trunk lid and the panel so that the tape adheres.

49

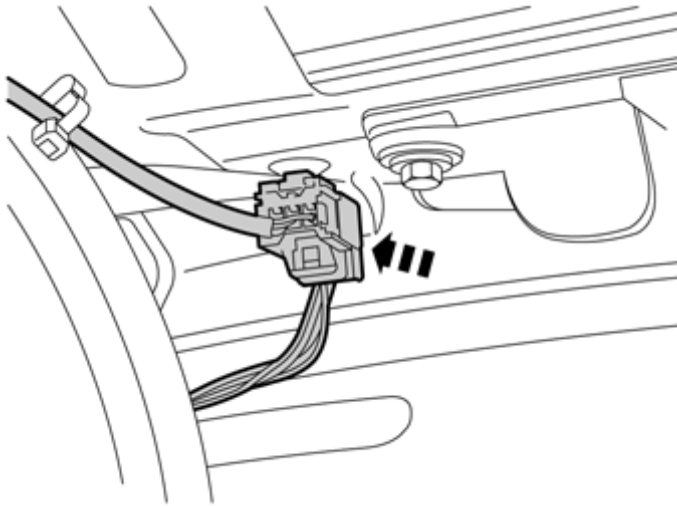

IMG-255747

Connect the number plate lighting connector on the inside of the trunk lid.

50

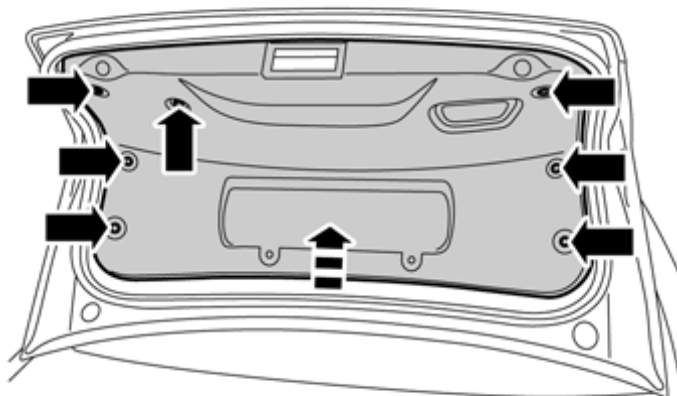

Reinstall the panel on the inside of the trunk lid.

IMG-255748



Installation instructions, accessories

Volvo Car Corporation Gothenburg, Sweden

51

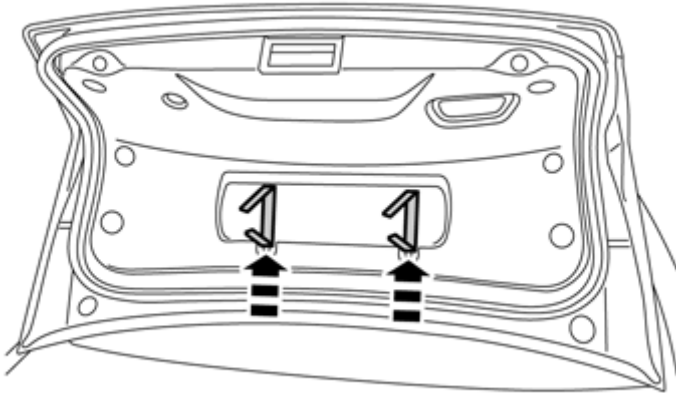

IMG-255749

Reinstall the warning triangle's holder and press the middle pins of the clips in.

52

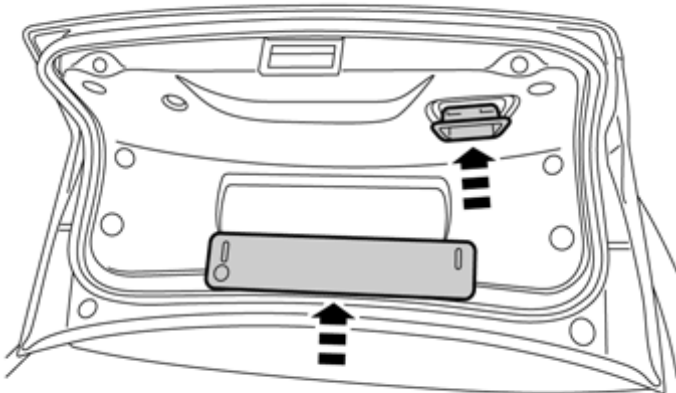

IMG-255750

Take the new inner handle from the kit and press it onto the boot lid.

Refit the warning triangle holder and the warning triangle on the boot lid.

Installing the parking assistance camera (PAC)



Installation instructions, accessories

Volvo Car Corporation Gothenburg, Sweden

53

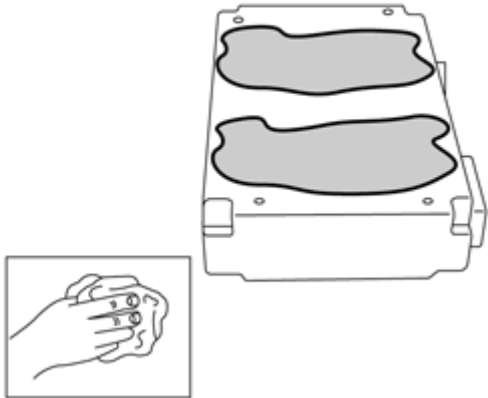

IMG-255751

Installing the parking assistance camera (PAC)

Take the control module from the kit.

Clean the two polished surfaces on the control module using isopropanol.

Wipe dry.

54

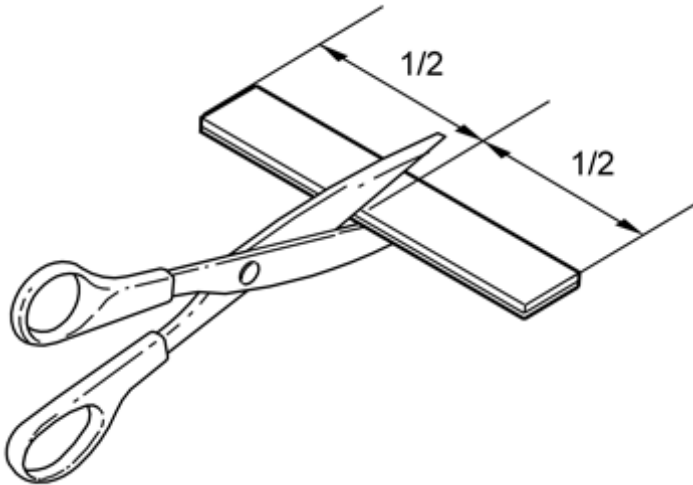

IMG-222282

Take two Velcro strips from the kit and cut them in the middle to create four equal parts.

55

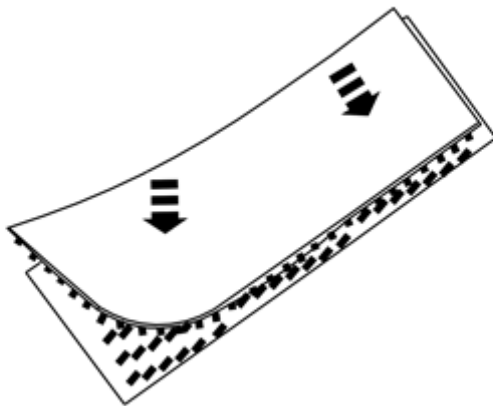

IMG-222283

Press the Velcro strips two and two.



Installation instructions, accessories

Volvo Car Corporation Gothenburg, Sweden

56

Remove the protective film from one side of the two attached Velcro strips.

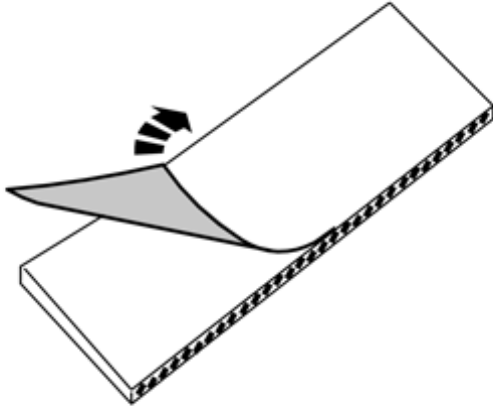

IMG-222285

57

Press the Velcro strips onto the cleaned surfaces of the control module.

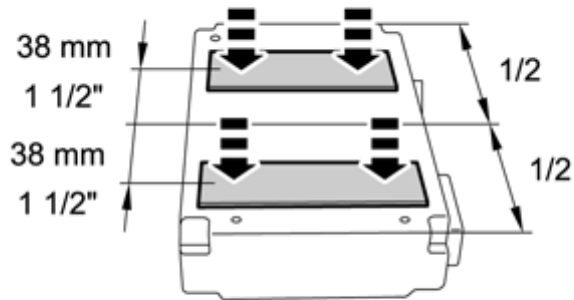

IMG-255752

58

Clean the surfaces under the tail lights with isopropanol. Wipe dry.

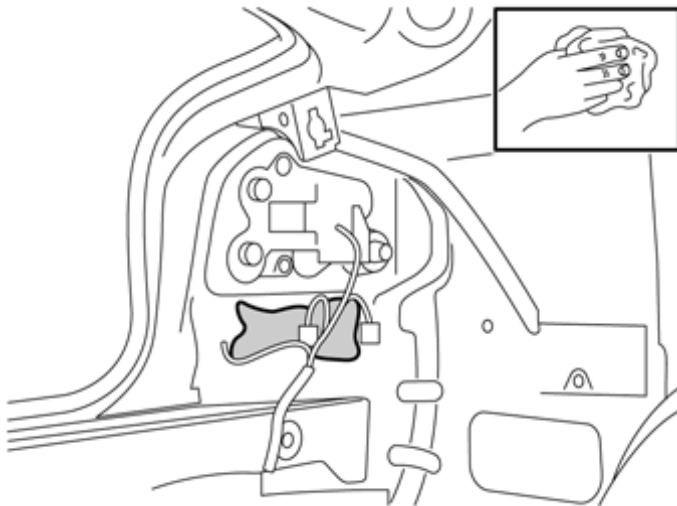

IMG-255754



Installation instructions, accessories

Volvo Car Corporation Gothenburg, Sweden

59A

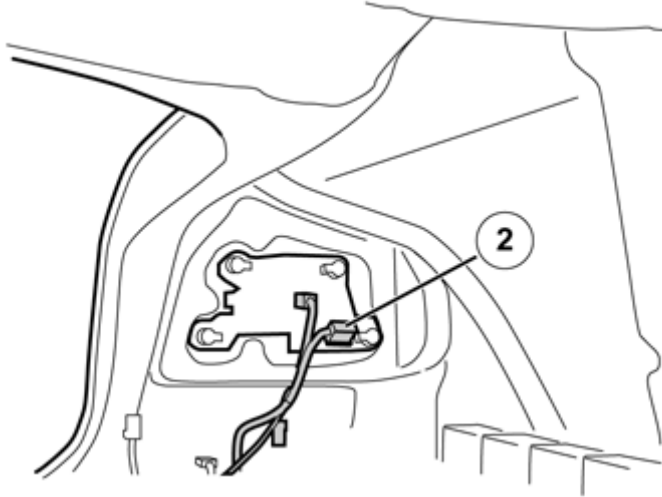

IMG-273804

59B

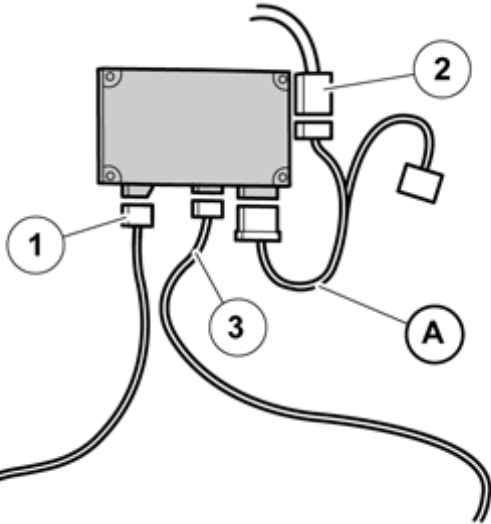

IMG-273823

59C

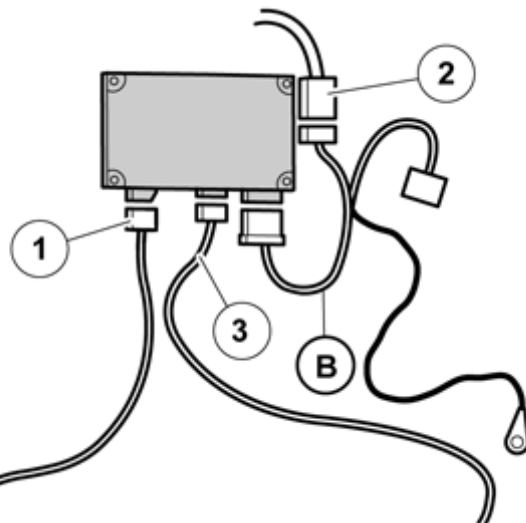

IMG-273824

Note!

The adapter cable A was included in a previous version of the kit for the parking camera.

The adapter cable B was included in a later version of the kit for the parking camera.

Both versions are suitable for all cars.

Illustration A

Connect the previously routed cable harness connector (1) to the right-hand connector on the control module.

Take the adapter cable A/B from the kit and connect the large green connector to the socket on the control module, as illustrated.

Connect the connector (2) on the pre-routed, taped cable harness for the power supply under the left-hand tail lamp, to the corresponding connector on the adapter cable.

Take the long remaining cable harness from the kit and connect the end with the gray connector (3) to the connector in the middle of the control module.

Clamp the adapter cable's remaining connector using the tie strap from the kit.

Figure B shows adapter cable A

Figure C shows adapter cable B



Installation instructions, accessories

Volvo Car Corporation Gothenburg, Sweden

60

Remove the protective film from the installed Velcro strips.

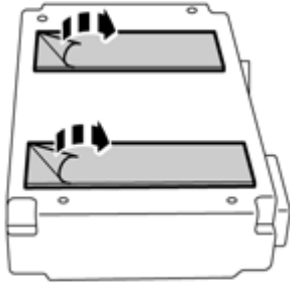

IMG-255753

61

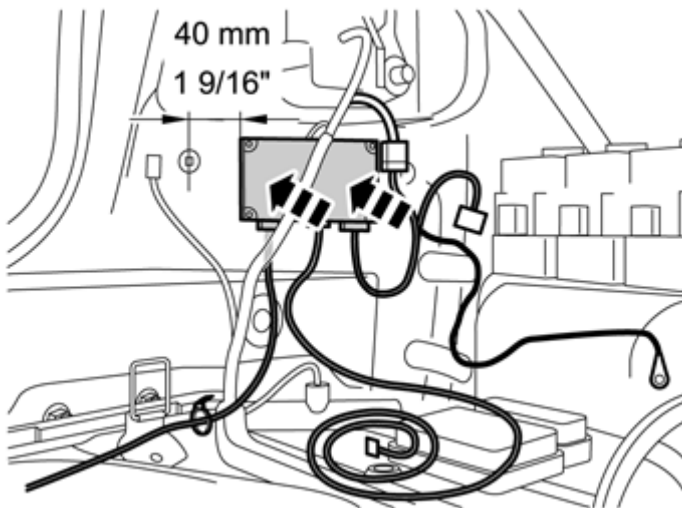

Press the control module upwards firmly as high as possible on the flat surface under the tail lamp, according to the measurements illustrated.

IMG-273825

62

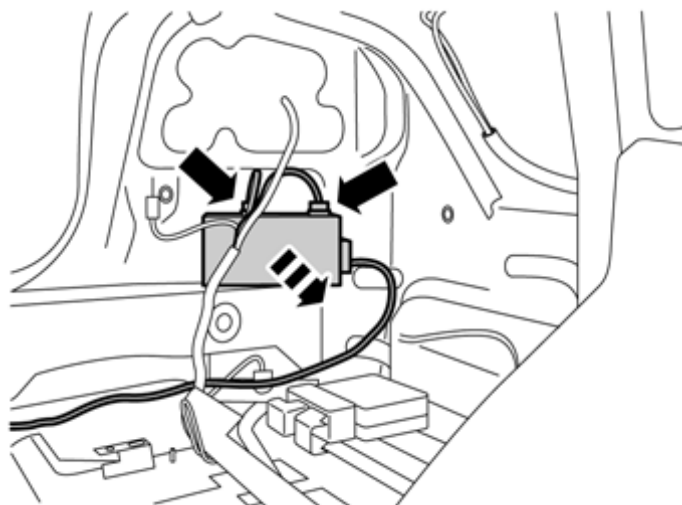

Applies to cars with a TRM module.

Remove the two connectors from the top of the TRM module.

Remove the TRM module from the Velcro strips on the plate under the rear lamp and place to one side.

IMG-255757



Installation instructions, accessories

Volvo Car Corporation Gothenburg, Sweden

63

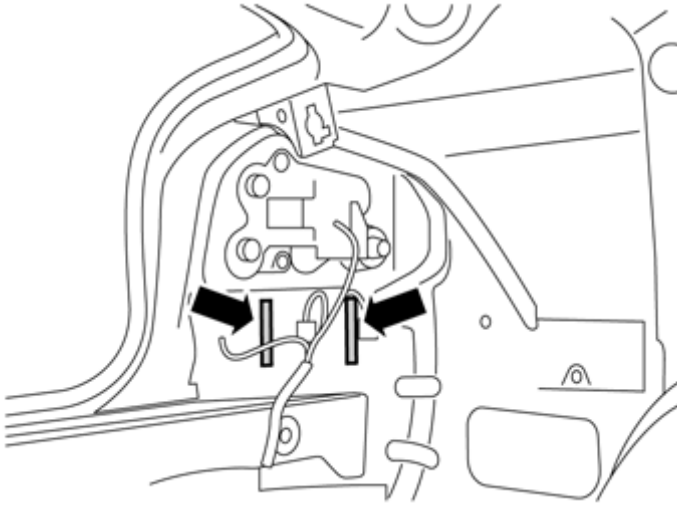

IMG-255758

Allow the old Velcro strips to remain in the body.

64

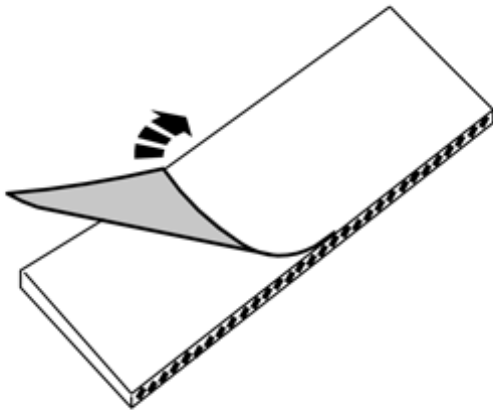

IMG-222285

Remove the protective film from the Velcro strips.

65

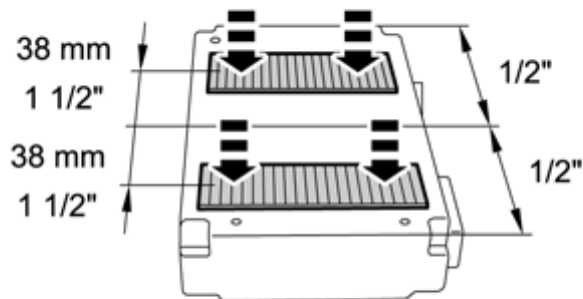

Press the Velcro strips on to the cleaned surfaces on the parking assistance camera (PAC).

IMG-255759



Installation instructions, accessories

Volvo Car Corporation Gothenburg, Sweden

66A

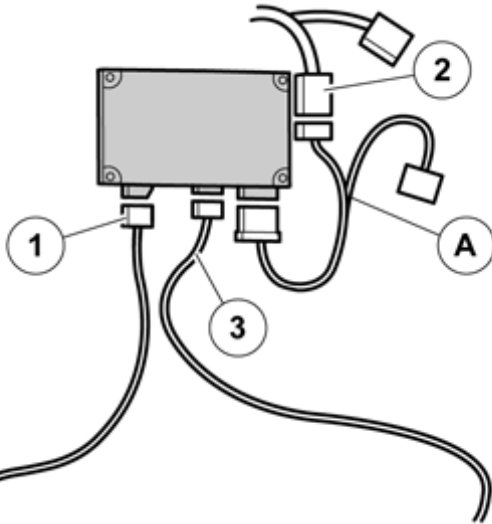

IMG-273826

Note!

The adapter cable A was included in a previous version of the kit for the parking camera.

The adapter cable B was included in a later version of the kit for the parking camera.

Both versions are suitable for all cars.

Figure A shows adapter cable A

Figure B shows adapter cable B

Connect the previously routed cable harness connector to the right-hand connector on the control module (1).

Take the adapter cable A/B from the kit and connect the large green connector to the socket on the control module, as illustrated.

Connect the connector (2) on the pre-routed cable harness for the power supply to the corresponding contact on the adapter cable.

Take the long remaining cable harness from the kit and connect the end with the gray connector (3) to the connector in the middle of the control module.

66B

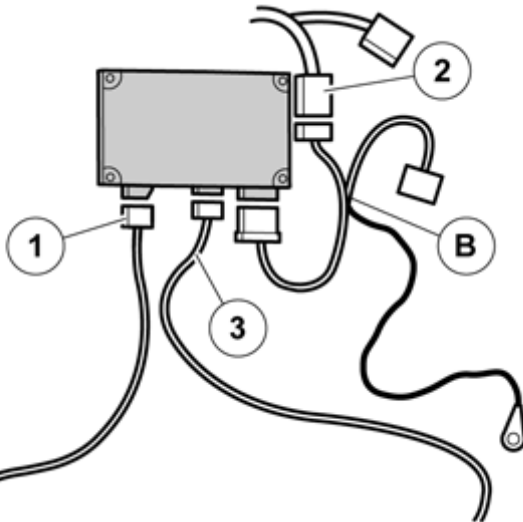

IMG-273863

Press the control module firmly onto the existing Velcro straps under the tail lamp.

67

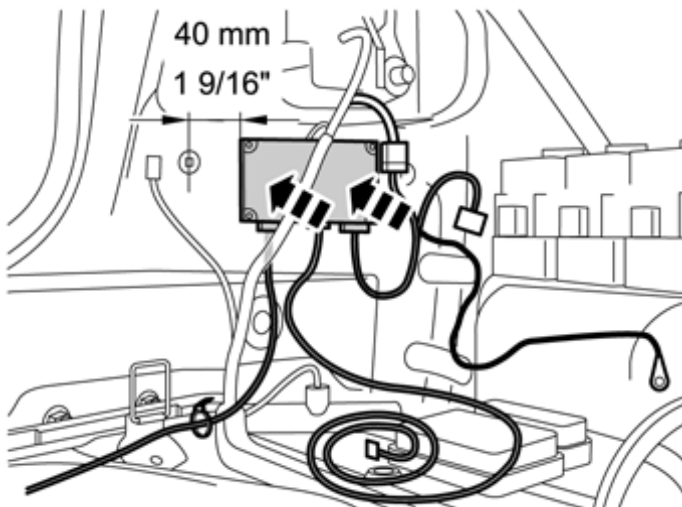

IMG-273864



Installation instructions, accessories

Volvo Car Corporation Gothenburg, Sweden

68

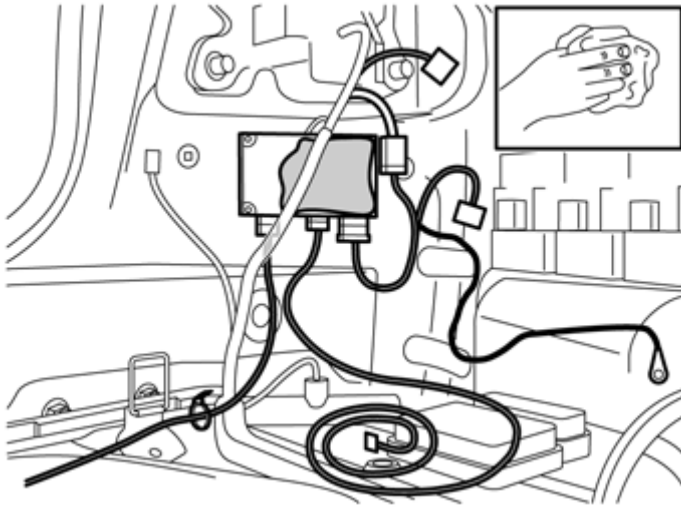

IMG-273865

Clean the marked surfaces on the control module with isopropanol. Wipe dry.

69

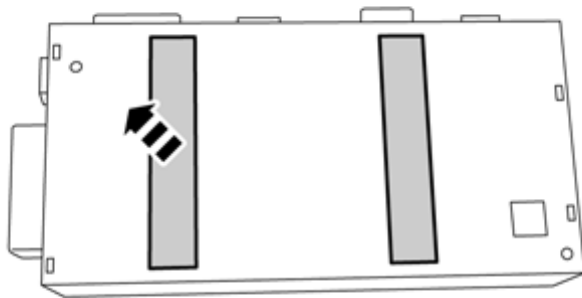

IMG-255763

Remove the marked Velcro strip from the TRM module.



Installation instructions, accessories

Volvo Car Corporation Gothenburg, Sweden

70

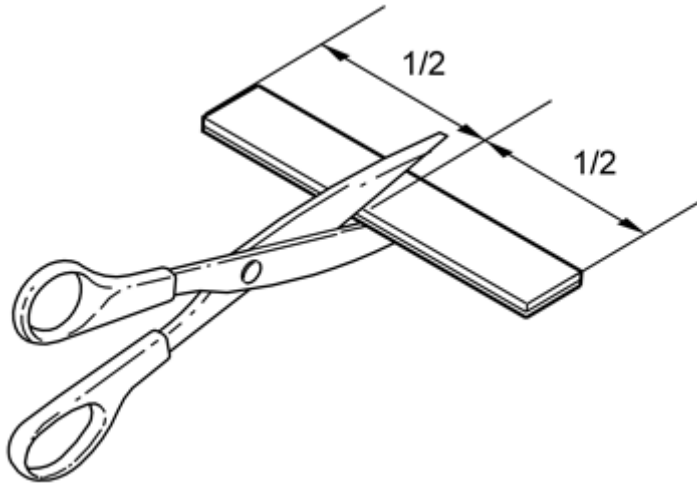

IMG-222282

Take two Velcro strips from the kit and cut them in the middle to create four equal parts.

71

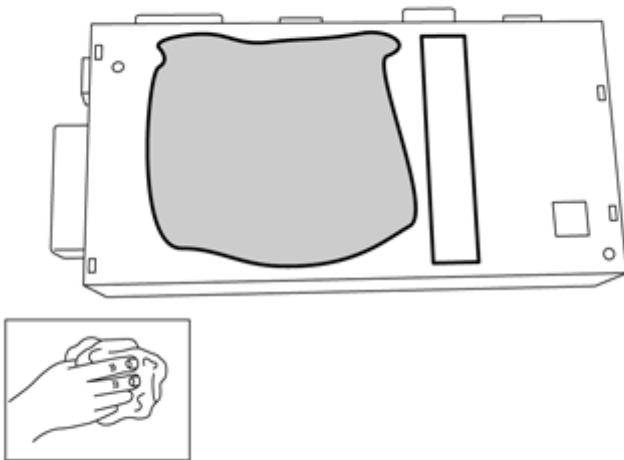

IMG-255764

Clean the marked surfaces on the TRM module with isopropanol. Wipe dry.

72

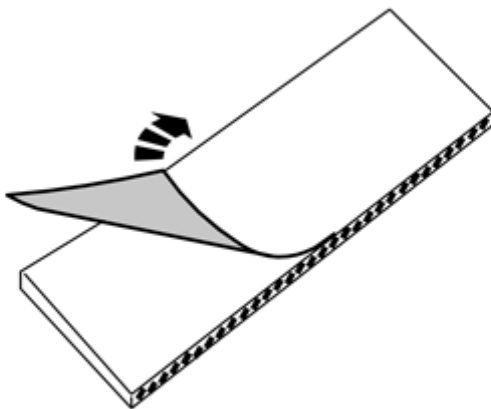

IMG-222285

Remove the protective film from one of the Velcro strips.



Installation instructions, accessories

Volvo Car Corporation Gothenburg, Sweden

73

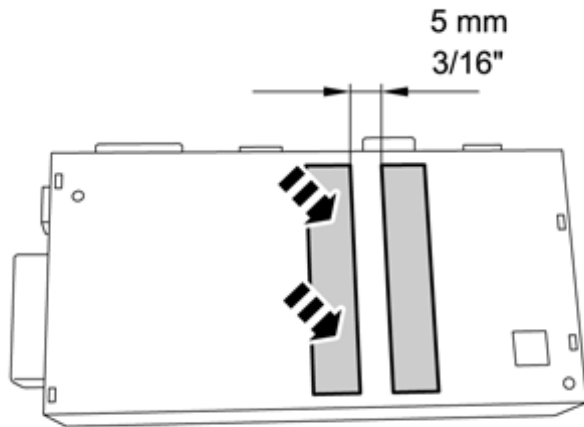

Press the Velcro strip on to the TRM module beside the other strip, as illustrated.

IMG-255765

74

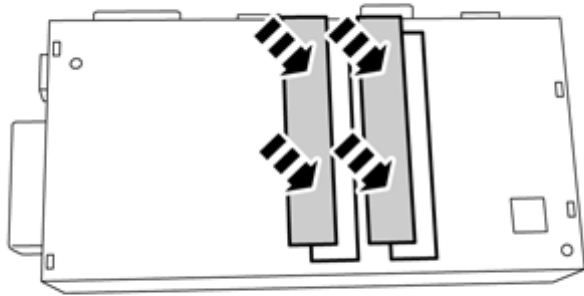

Press the two Velcro strips onto the TRM module's two existing Velcro strips.

IMG-255766

75

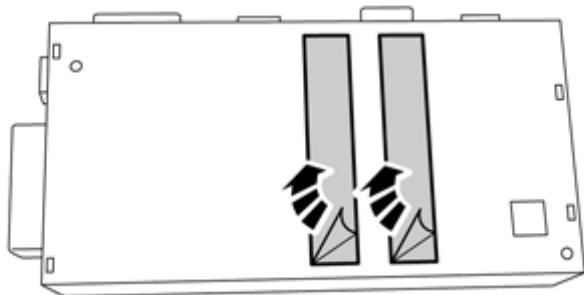

Remove the protective film from the Velcro strips.

IMG-255767



Installation instructions, accessories

Volvo Car Corporation Gothenburg, Sweden

76

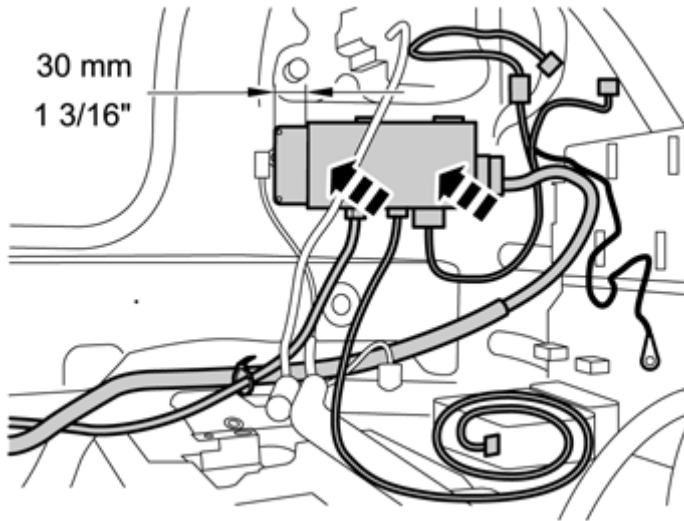

IMG-273866

Press the TRM module onto the control module securely, as illustrated.

77

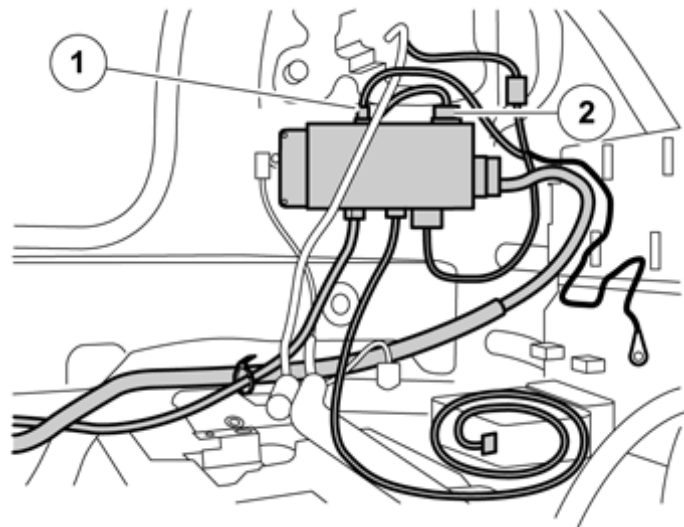

IMG-273867

Connect the remaining green connector (1) on the adapter cable for the power supply to the corresponding socket in the TRM module.

Connect the remaining gray connector (2), which was removed from the TRM module.



Installation instructions, accessories

Volvo Car Corporation Gothenburg, Sweden

78

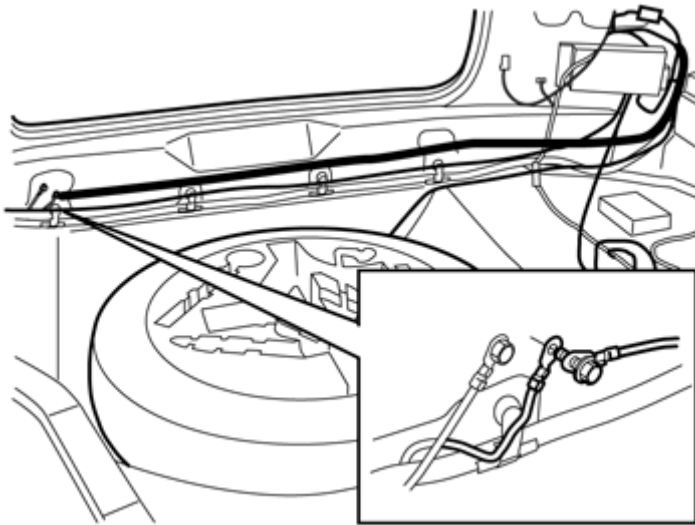

IMG-273869

Steps 70-71 only apply to cars with adapter cable B for the power supply

Route the long ground lead in the adapter cable to the right-hand side of the rear harness.

Connect the cable to the lower of the ground screws and tighten the screw with **10 Nm (7.5 lbf.ft.)**

79

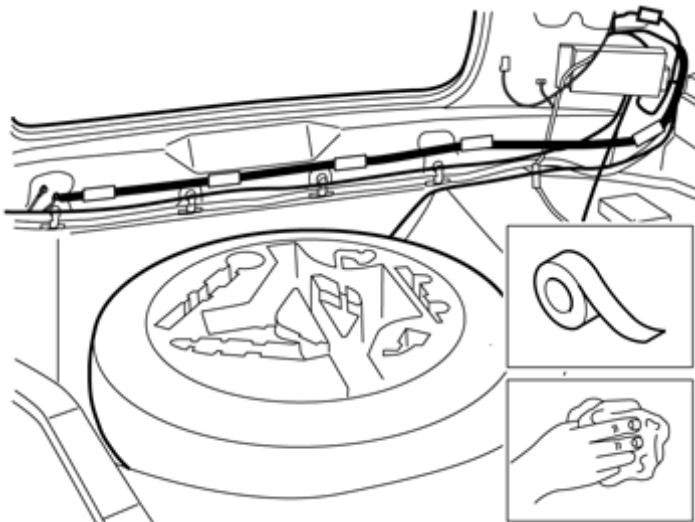

IMG-273870

Wash the rear crossmember using isopropanol where the ground lead is to be taped. Wipe dry.

Secure the cable using a wide piece of silver/fabric tape or similar.

Note!

The ground lead must only be taped at the rear crossmember, it must not be secured by the thick cable harness.

80

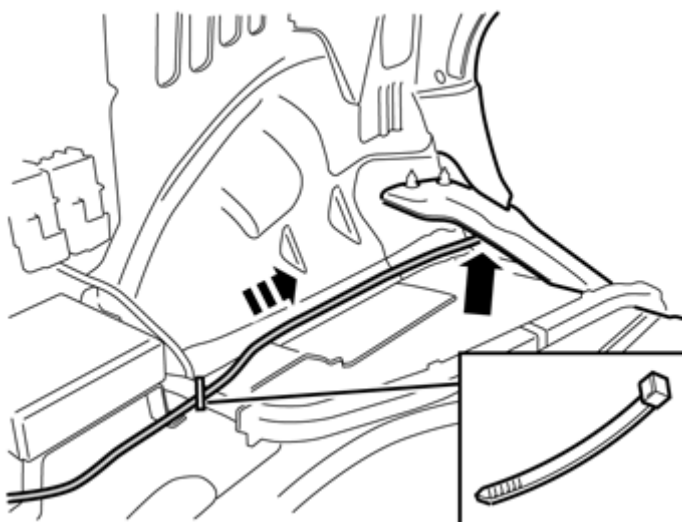

IMG-257676

Route the previously connected cable harness inside the insulation panel at the left-hand rear wheel arch and out through the hole in the body.

Take a tie strap from the kit and secure the cable at the fuse holder's cable harness.



Installation instructions, accessories

Volvo Car Corporation Gothenburg, Sweden

81

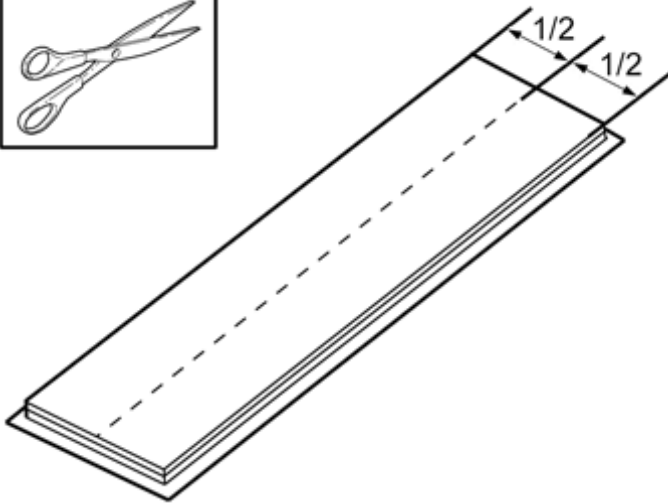
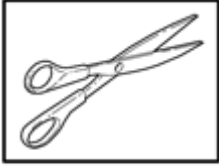

IMG-354975

Remove the foam tape from the kit and split it in the centre.

82

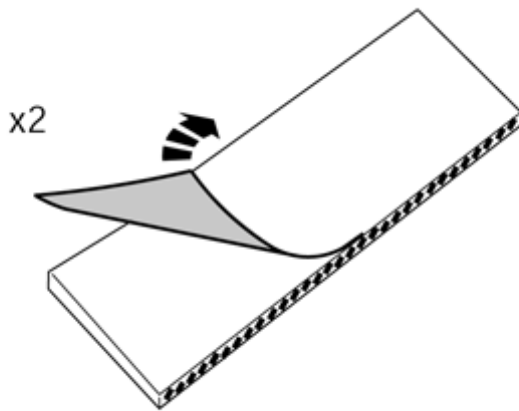

IMG-241925

Remove the protective film from the foam tape.

83

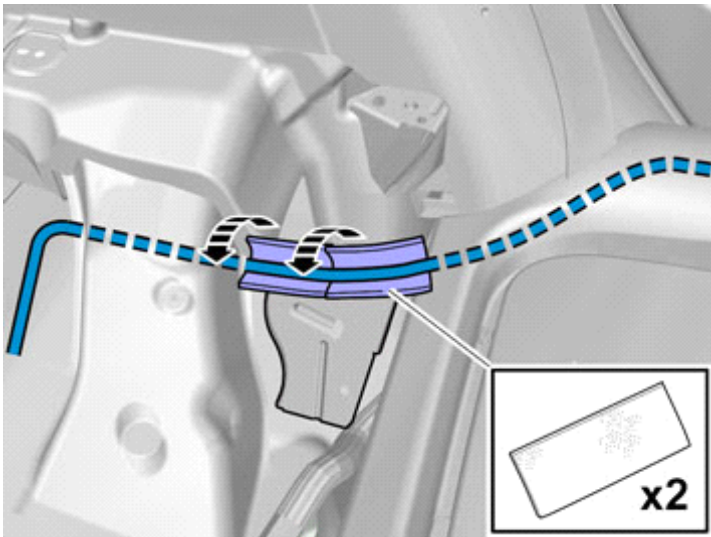

IMG-353731

Apply the foam tape around the wiring to protect the cable from sharp edges.



Installation instructions, accessories

Volvo Car Corporation Gothenburg, Sweden

84

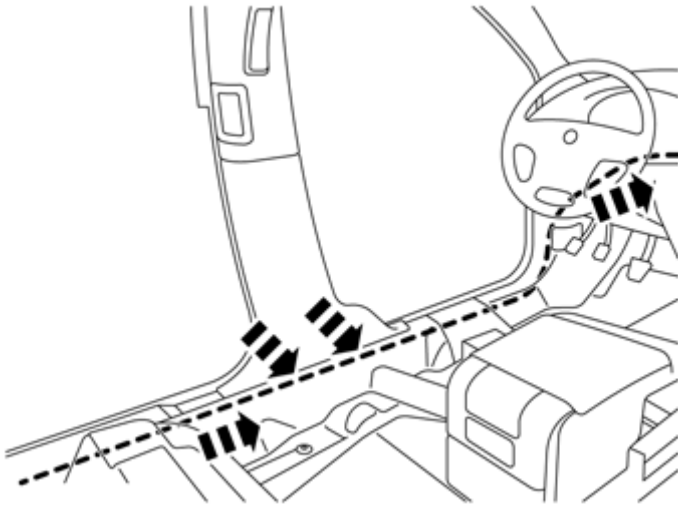

IMG-255771

Pull out the B post panel at the lower edge until the two clips release.

Continue to route the cable harness inside the B post panel and forwards in the car. Route the cable harness along the left-hand side, in front of the floor and insulation panels, up to the front edge of the door opening.

85

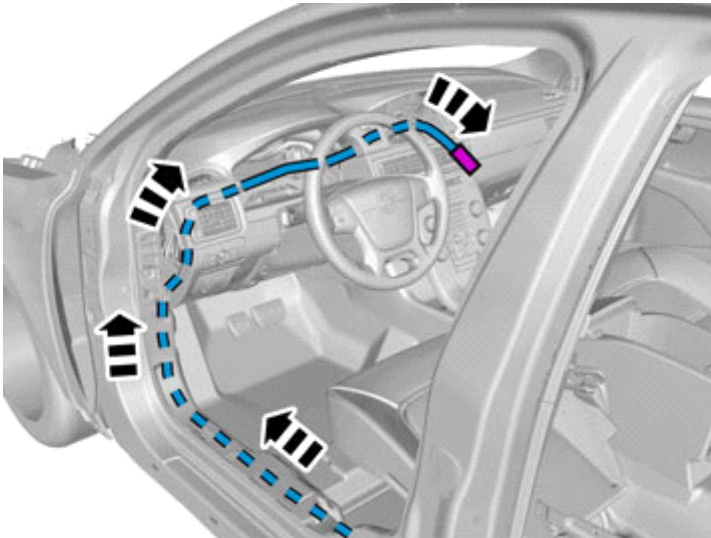

IMG-353574

Only applies to left-hand drive vehicles

Route the cable harness inside the floor and insulation panels, up on the A pillar slightly, and then at an angle upwards, between the A pillar and the end panel, towards the dashboard. Route the cable harness to the location for the screen in the dashboard.

Place the cable harness so that it does not come into contact with sharp edges or moving parts under the dashboard.



Installation instructions, accessories

Volvo Car Corporation Gothenburg, Sweden

86

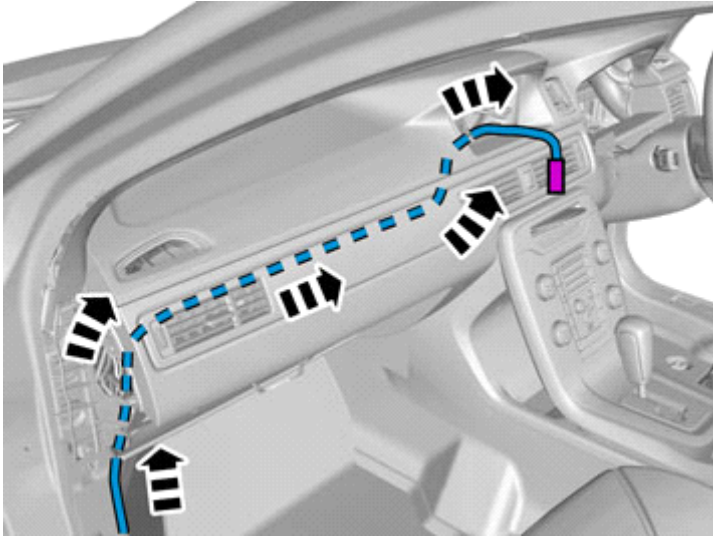

IMG-353581

Only applies to right-hand drive vehicles

Take a piece of wire and insert it by the air ducts through the hole for the screen. Pull it out to the left, above the glove compartment and out through the left-hand end of the dashboard.

Tap the connector on the cable to the screen by the wire.

Pull the cable up to the location for the screen and out through the hole in the dashboard.

87

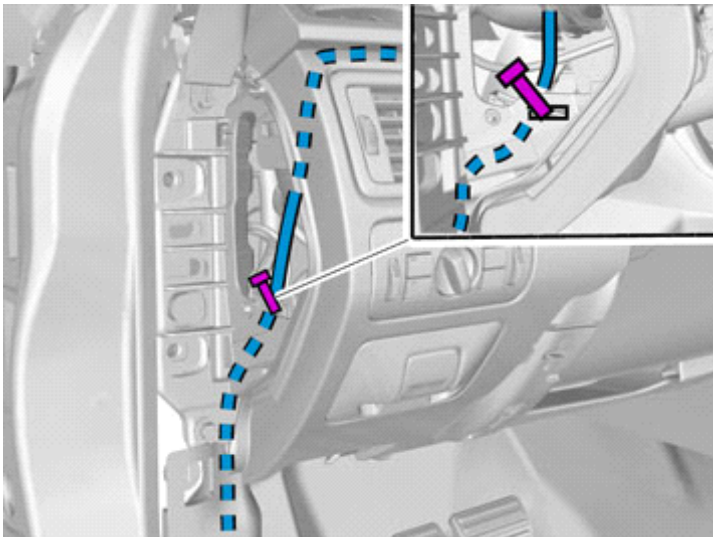

IMG-353636

Applies to all vehicles

Take a tie strap from the kit and secure the cable in the hole on the end as illustrated.

88

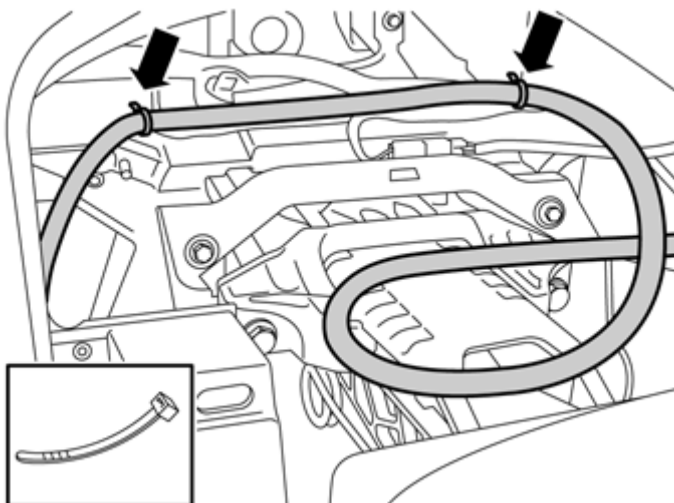

IMG-255775

Only applies to left-hand drive vehicles

Take two tie straps from the kit and clamp the cable at the existing cable harnesses inside the dashboard as illustrated.



Installation instructions, accessories

Volvo Car Corporation Gothenburg, Sweden

89

Applies to all vehicles with 5 inch ICM display

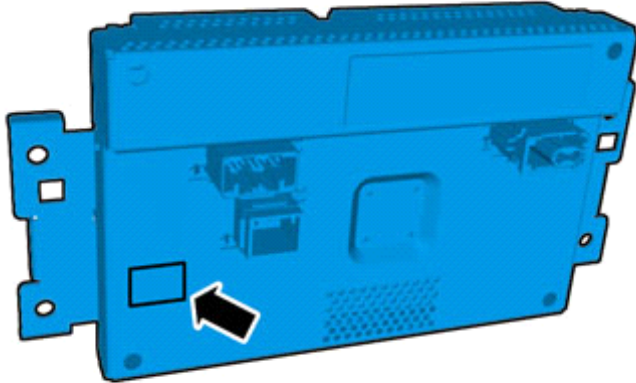

Note!

If there is no connection, replace the display.

IMG-348526

90

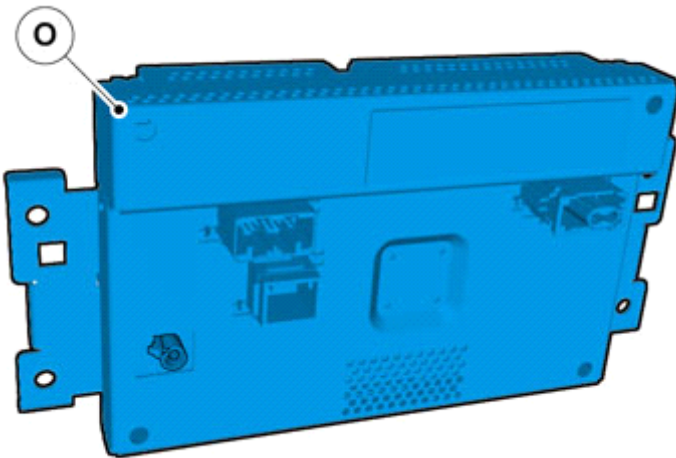

IMG-348747

91

Applies to all vehicles

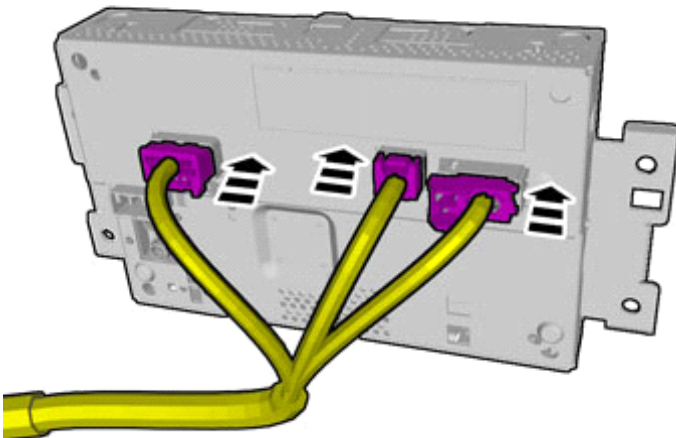

Note!

The number of connectors, cables and cable ties can vary depending on the vehicle's equipment level.

Plug in the connectors.

IMG-348748



Installation instructions, accessories

Volvo Car Corporation Gothenburg, Sweden

92

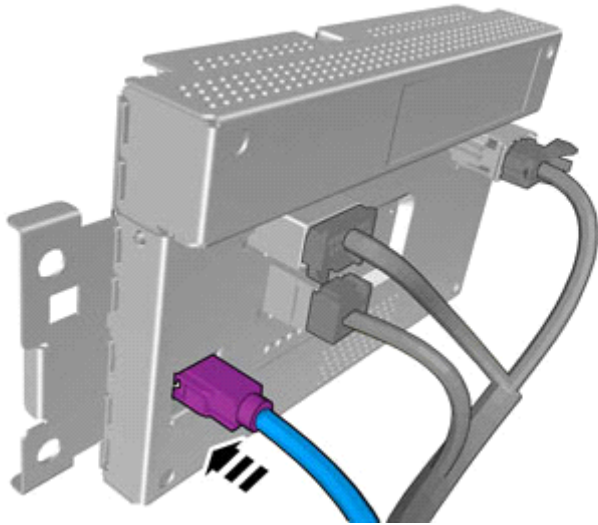

IMG-352266

Applies to vehicles with 5 inch ICM display

Plug in the connector.

93

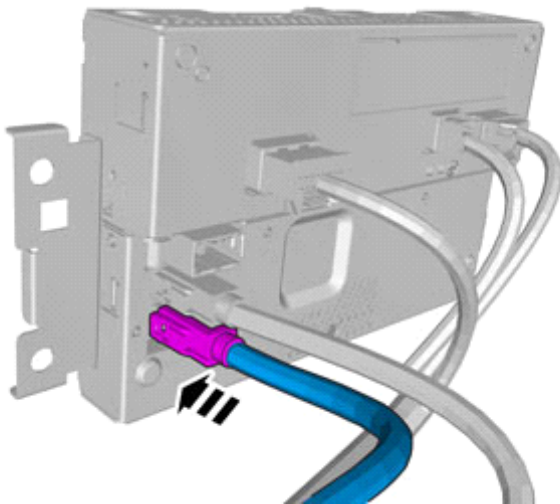

IMG-352267

Applies to vehicles with 7 inch ICM display

Plug in the connector.



Installation instructions, accessories

Volvo Car Corporation Gothenburg, Sweden

94

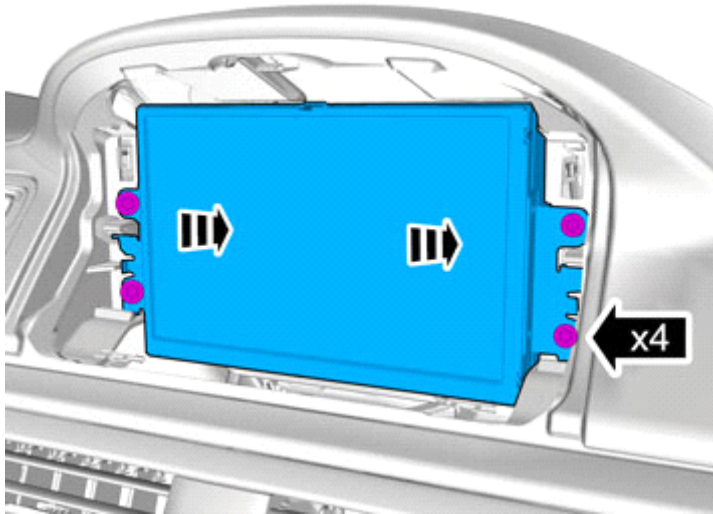

IMG-349904

Applies to all vehicles

Reinstall the panel.

Install the screws.

Reinstall the detached components in reverse order.

Removal

95



IMG-382371

Removal

Note!

Orientation view



Installation instructions, accessories

Volvo Car Corporation Gothenburg, Sweden

96

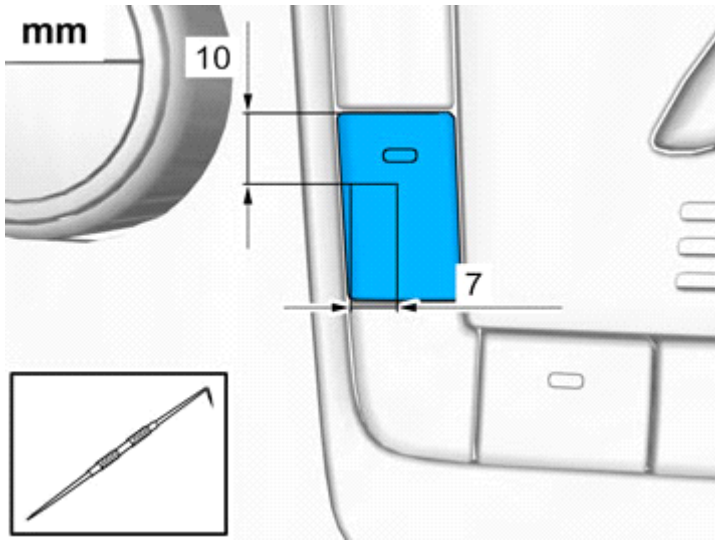

IMG-381005

97

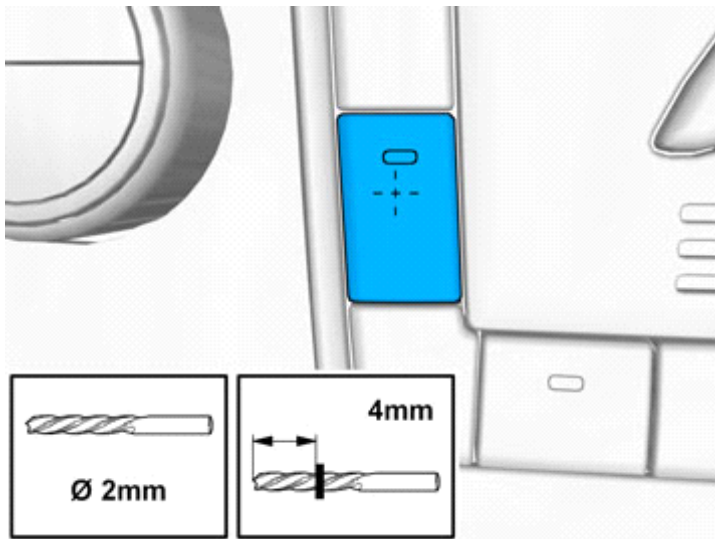

IMG-381006

98

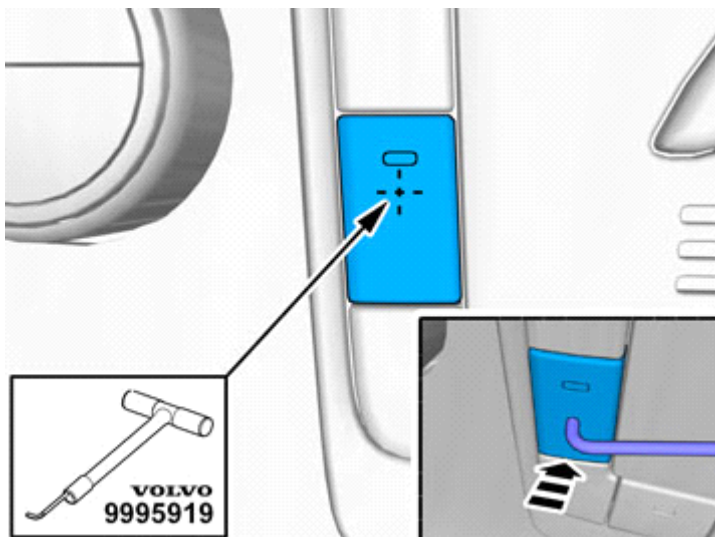

IMG-381020



Installation instructions, accessories

Volvo Car Corporation Gothenburg, Sweden

99

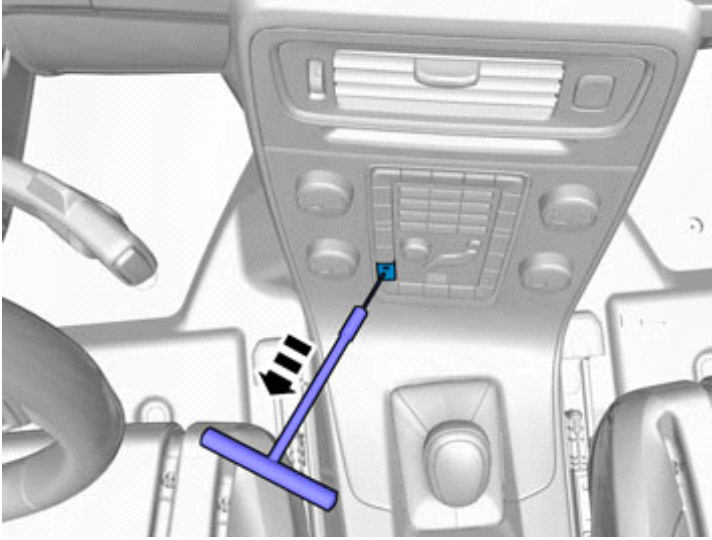

IMG-380996

Accessory installation

100

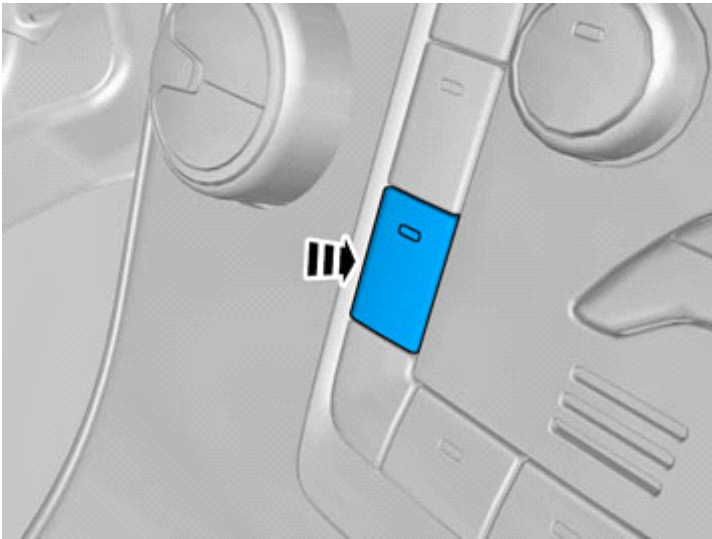

IMG-382374

Accessory installation

Install the component from the accessory kit.

Installation



Installation instructions, accessories

Volvo Car Corporation Gothenburg, Sweden

101

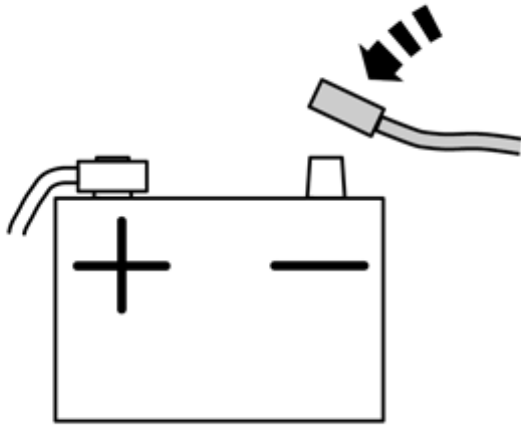

IMG-336901

Installation

Reconnect the battery negative lead

102

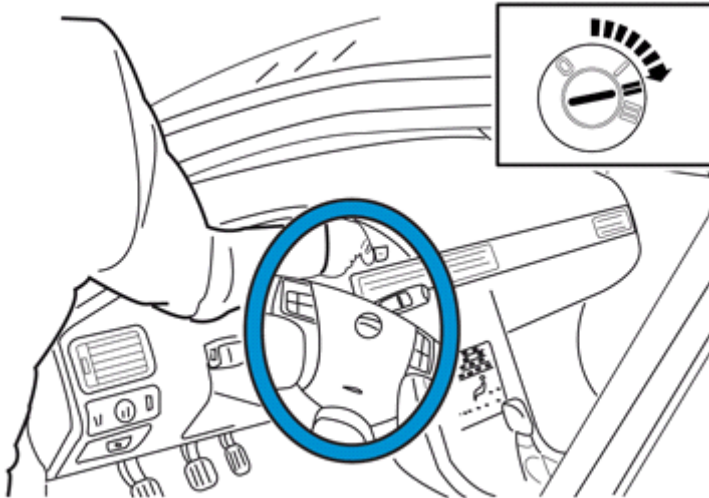

IMG-336904

Caution!

When the ignition is to be switched on for the first time after the battery has been disconnected, this must be done whilst by standing outside the vehicle, stretching your arm in and avoiding the working area for the airbags.

Set the ignition switch to position II.

103

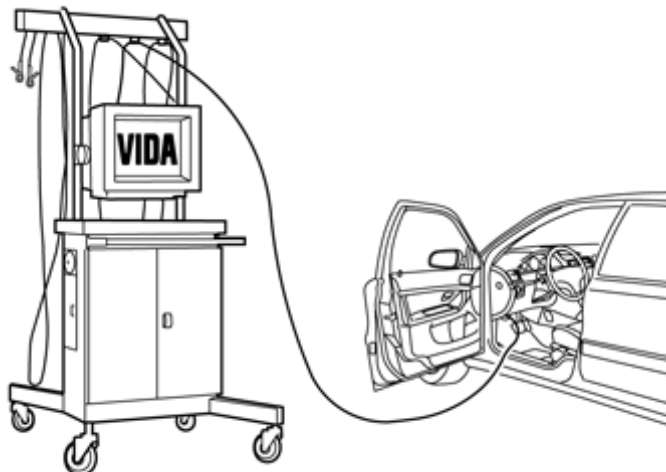

IMG-242268

Download software (application) for the accessory's function according to service information in VIDA. See VIDA or accessories catalogue for article number on software.



Installation instructions, accessories

Volvo Car Corporation Gothenburg, Sweden

104

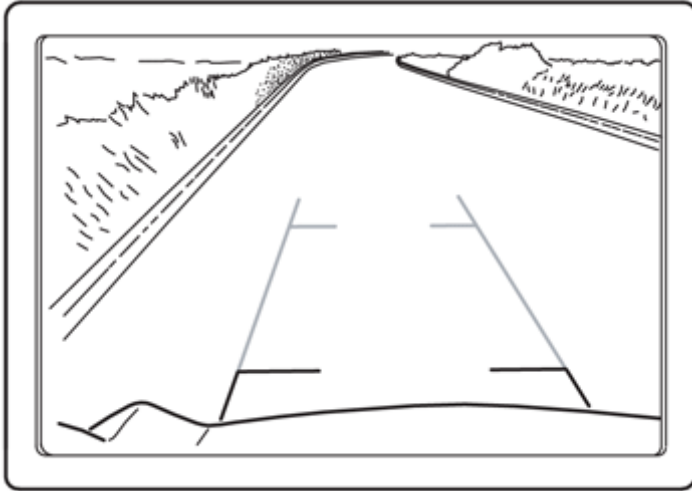

IMG-354602

Perform a function test as follows:

Engage reverse gear.

The display is activated.

Wait for the message "Update Environment" to appear on the screen.

Follow the on-screen instructions.

Switch off the ignition for at least 10 seconds.

Turn the ignition on.

The display is activated.

Check that the support lines appear on the screen and that these react to steering wheel movements.